



KIT INSTRUCTIONS

# Evacuated Tube Collector 10 Tube Additional Pitched Roof Kit

Kit Part No. 5130243

THESE INSTRUCTIONS CONTAIN INFORMATION FROM THE FOLLOWING BOOKLETS:  
Baxi Solarflo™ Installation Guide (Part No. 5130226), Commissioning Guide (Part No. 5130227) and  
Pitched Roof Kit Instructions (Part No. 5130229).

The User Guide Booklet  
(Part No. 5130228) should be read  
in conjunction with these  
instructions.

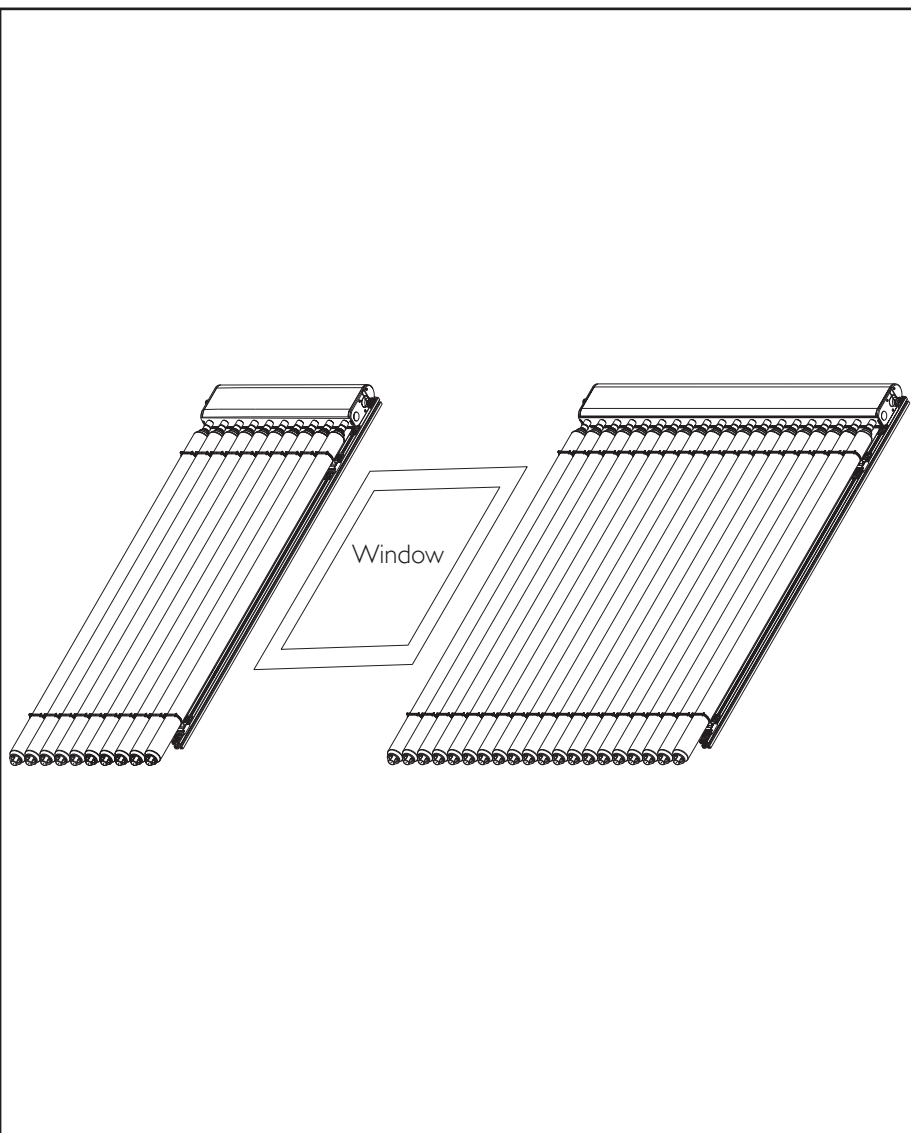

Please leave these instructions with the  
User for Safe Keeping

## Installation Options

The additional 10 tube pitched roof kit is intended for use when it is not possible to achieve a correctly sized system via the standard kits, due to roof obstructions such as a inroof opening window.

The 10 tube pitched roof kit is only recommended for use with the 20 tube pitched roof kit part no. 5130214.

This additional kit is not intended for use as a East West kit.

## Content

Section	Page
1.0 Introduction to Solar	3
2.0 Solar Collector Specifications	4
3.0 Pump Station Specifications	5
4.0 Solar Controller	6
5.0 Ancillary Components	7
6.0 General	8
7.0 Installation of Collector Sensor	10
8.0 Installation of Pump Station	11
9.0 Installation of Solar Controller	13
10.0 Site Requirements	17
11.0 Installation of Solar Collector	19
12.0 Commissioning of System	25
13.0 Commissioning of Hydraulic Station	28
14.0 Commissioning of Solar Controller	29
15.0 Commissioning Record	42
16.0 Maintenance	45
17.0 Fault Finding	46
18.0 Spares	49
19.0 Warranty	51

© Baxi Heating UK Ltd 2011. All rights reserved. No part of this publication may be reproduced or transmitted in any form or by any means, or stored in any retrieval system of any nature (including in any database), in each case whether electronic, mechanical, recording or otherwise, without prior written permission of the copyright owner, except for permitted fair dealing under Copyrights, Designs and Patents Act 1988.

Applications for the copyright owner's permission to reproduce or make other use of any part of this publication should be made, giving any details of the proposed use to the following address:

The Company Secretary, Baxi Heating UK Limited, Brooks House, Coventry Road, Warwick. CV34 4LL

Full acknowledgement of author and source must be given.

WARNING: Any person who does any unauthorised act in relation to a copyright work may be liable to criminal prosecution and civil claims for damages.

## 1.1 Description

Thank you for purchasing a high quality Baxi Solarflo™ Solar Thermal Domestic Hot Water System.

The sun is the ultimate source of most of our renewable energy supplies. Energy from the sun is clean and abundant.

There is a widely held opinion that the UK does not have enough sun to make solar systems worthwhile. In fact parts of the UK have annual solar radiation levels equal to 60% of those experienced at the equator.

However, this energy is not received uniformly throughout the year. Some 70% of UK annual radiation is received over the period April to September and 25% is received in the months of June and July.

Solar water heating technology captures energy from the sun and transfers this to a water heater to raise the water temperature therefore reducing the reliance on fossil fuel energies such as gas, oil and electricity. Up to 60% of a dwelling's annual hot water requirement can be provided by a solar water heating system. The balance is provided by traditional means via a second heat exchanger connected to a fossil fuel boiler or electrical heating by electric boiler or immersion heater.

The Baxi Solarflo™ water heating system provides all the principal components required for an efficient solar water heating system. The sun's energy is captured by a series of solar collectors through which a special heat transfer fluid is pumped. As the fluid passes through the collector its temperature is raised. The heated fluid is circulated through a heat exchanger coil in the base of the solar storage cylinder transferring the heat gained to the stored water; gradually raising its temperature. The cooled fluid then returns to the collector to be heated again. Heating by the solar coil is controlled by a solar differential temperature controller that ensures the system will only operate when there is useful solar heating gain at the collector. As the sun's energy input to the collector is variable supplementary heating by a conventional boiler or electric immersion heater should be provided. The optional cylinders that can be supplied with the Baxi Solarflo™ package provide a supplementary heat exchanger coil and immersion heater as standard.

## 1.2 General

Avoid the use of hacksaws if at all possible. Using the correct pipe cutting tools will reduce the amount of debris in the system prior to flushing.

Read in conjunction with Solar Collector Guide.

Fig. 1- Schematic

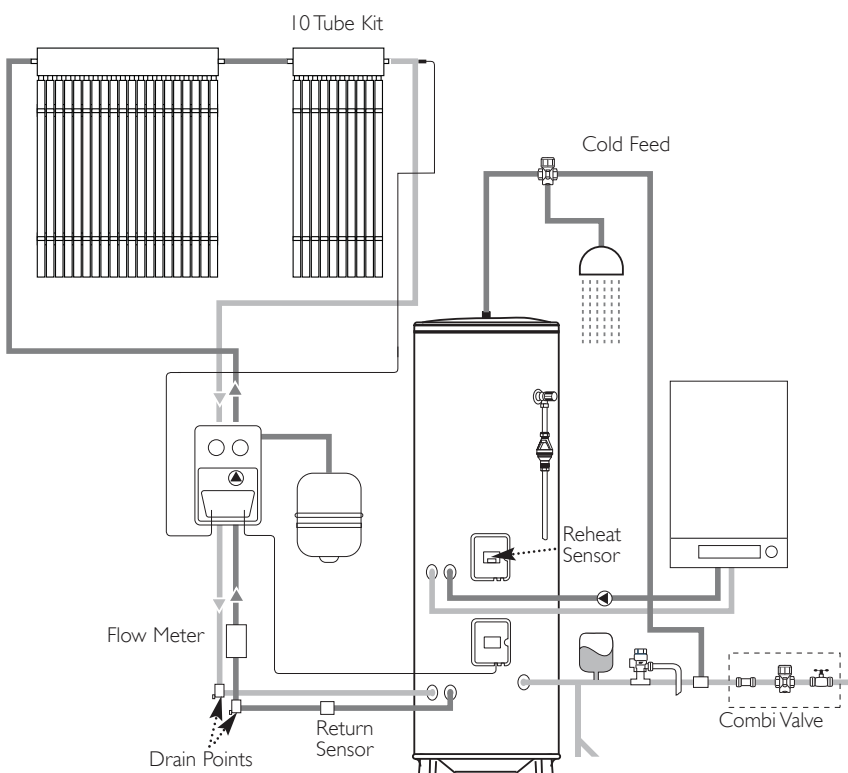

## 2.0 Solar collector specifications

Fig. 2

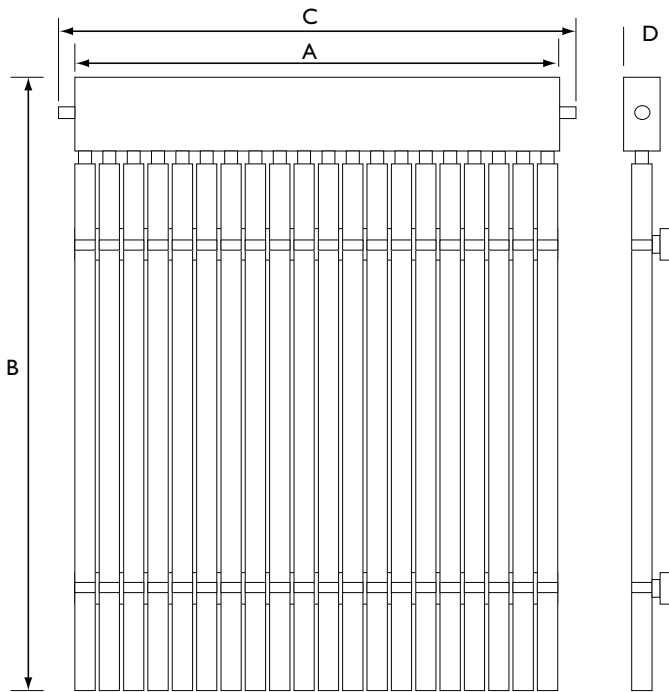

Table of dimensions (mm)

	20 tube	10 tube
A	1418	1209
B	1996	1996
C	1475	737.5
D	97	97

All dimensions shown in mm

### 2.1 Technical Data

	20 tube	10 tube
Gross area:	2.83m <sup>2</sup>	1.45m <sup>2</sup>
Net area:	2.00m <sup>2</sup>	1.076m <sup>2</sup>
Weight:	54.8 kg	27.4 kg
Fluid Volume:	3.8 litres	1.9 litres
Pressure:	8 bar	8 bar
Absorption:	95%	95%
Emission:	5%	5%
Stagnation temp:	286°C	286°C
Glass:	65mmØ Low-iron - transmission 0.92	
Light transmittance:	>90.8% ± 2%	

### Coefficients of efficiency (20 & 10 tubes)

(determined in the sun simulator SUSI 1)

$$\eta = \eta_0 - a_1 \cdot (t_m - t_a) / G - a_2 \cdot (t_m - t_a)^2 / G$$

Based on:	aperture area	absorber area
$\eta_0 =$	0.773	0.830
$a_1 =$	1.43 W/m <sup>2</sup> K	1.53 W/m <sup>2</sup> K
$a_2 =$	0.0059 W/m <sup>2</sup> K	0.0063 W/m <sup>2</sup> K

Fig. 3

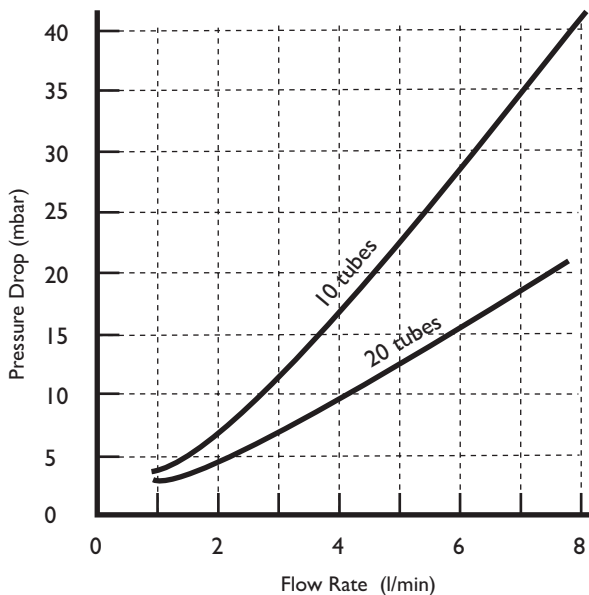
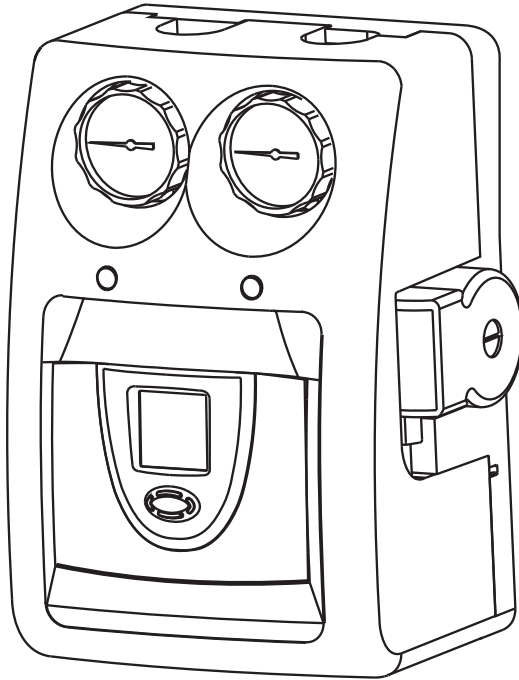

Fig. 4



## 3.0 Pump station specifications

### 3.1 Technical Data

Dimensions (Height/Width/Depth)	375/250/190mm
Flow and return connections (compression fittings)	22mm
Maximum working temperature:	120°C
Maximum working pressure:	6 bar
Pressure Relief Valve setting:	6 bar
Circulating Pump:	Grundfos UPS 25-60 / Wilo ST 25/6
Circulating Pump voltage:	230/240 V ~
Power consumption Setting 1:	40W
Setting 2:	60W
Setting 3:	80W
Maximum Pump Head:	6 metres
Maximum Pump Capacity:	4.5 m <sup>3</sup> /h / 3.5 m <sup>3</sup> /h
Flow meter scale:	2 to 15 l/min

### Features

Air Separator

Adjustable Control Valves

Drain Point

Temperature Gauges

Flow Gauge

Fig. 5

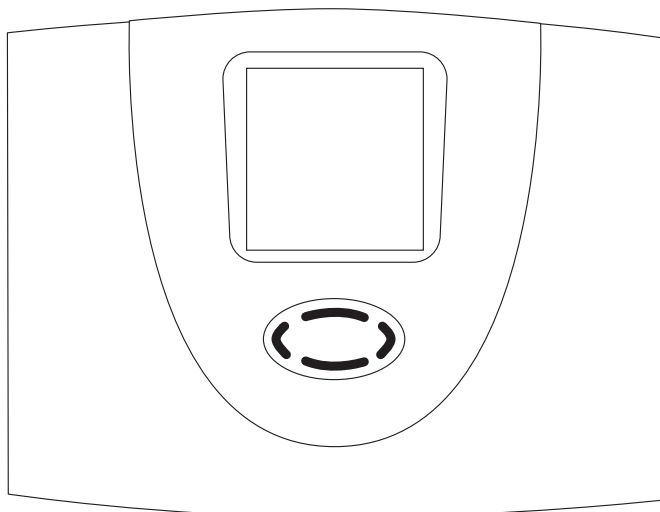

#### 4.1 Technical Data

Housing Material	100% recyclable ABS
Dimensions L x W x D in mm weight	175 x 134 x 56 360 g
Ingress protection	IP40 according to VDE 0470
<b>Electrical values</b>	
Operating voltage	230/240V ~ 50 Hz
Interference grade	N according to VDE 0875
Max. conductor cross-section 240V-connections	2.5 mm <sup>2</sup> fine-strand/single-wire
Temperature sensor / temperature range	PTF6 - 25°C to 200°C PT1000, 1,000 kΩ at 0°C
Test voltage	4 kV 1 min according to VDE 0631
Switching voltage	230V / 240V
Capability per one switch output	1A / 230VA for cos j = 0.7-1.0
Total capability of all outputs	2A / 460VA maximum
Fuse protection	fine-wire fuse 5 x 20mm, 2A/T (2 amperes, slow)

#### Features

Menu driven operation

System monitoring

Solar gain measurement

Suitable for flat plate and evacuated tube type collectors

Auxiliary heat source control

Can be used in a number of system configurations see Fig. 15

**NOTE: This controller is suitable for S plan and Y plan systems.**

However, in the event of an installation having a 'Y' plan boiler system that is to be controlled by the solar controller, a relay is required (not supplied). This is available as a Baxi Spares Item, Code No. 5122765.

Fig. 6

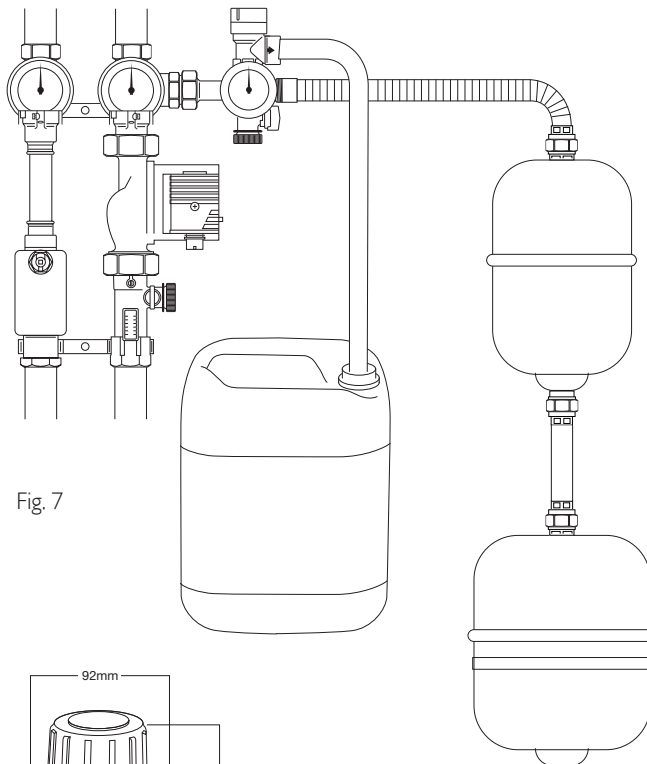
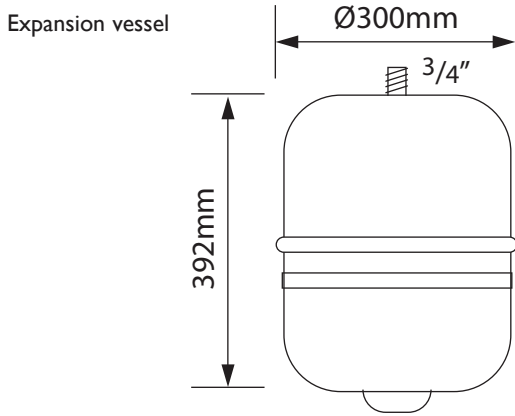

Fig. 7

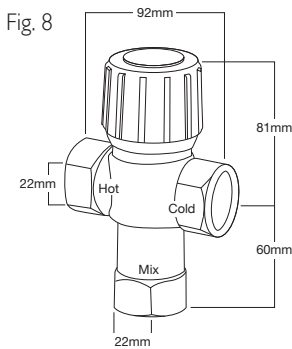
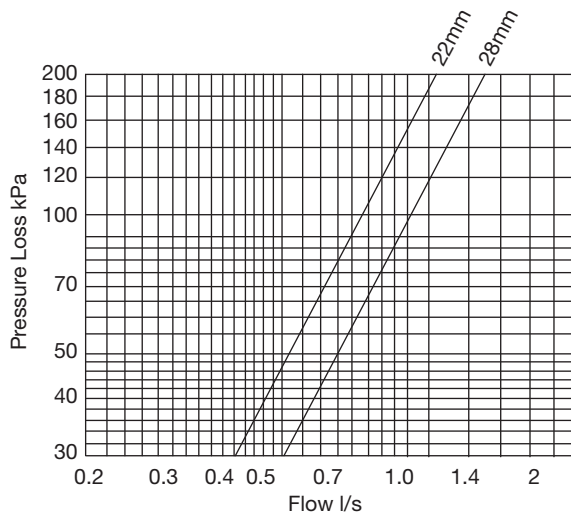

Fig. 9



## 5.0 Ancillary components

### 5.1 Expansion Vessel

Membrane expansion tanks for solar primary heating circuit. Manufactured according to the Directive PED 97/23/CE (approved noZ-DDK-MUC-02-396876-04).

Factory set charge pressure 2.5 bar.

Butyl membrane suitable for solar primary heating fluid, DIN 4807-3 approval.

Maximum working temperature +110°C.  
Maximum percentage of glycol 40% (Pre-mixed).  
Connection: 3/4" BSP male parallel

Expansion vessel supplied with wall mounting bracket and self sealing vessel connection that will allow removal of the vessel for maintenance without losing solar heat transfer fluid.

Under the following circumstances, a protection vessel should be used in the Return Leg of the solar loop from the pump station. The following distances should be observed:

20 tube collectors should have a Protection Vessel fitted if the expansion vessel is less than 8 metres away from its nearest collector. This should be sited at a suitable point between the expansion vessel and nearest collector.

30 tube collectors should have a Protection Vessel fitted if the expansion vessel is less than 12 metres away from its nearest collector. This should be sited at a suitable point between the expansion vessel and nearest collector.

Instances where a protection vessel should be included		
Pipe Diameter	20 tube system	30 tube system
	Distance to nearest collector	
15mm	<8m	<12m
22mm	<4m	<6m

The size of the protection vessel should be at least the combined volume of the following:

Total Collector volume + total pipe work volume from collector to protection vessel.

For positioning on protection vessel (Fig. 7).

### 5.2 Solar Heat Transfer Fluid

Pre-mixed (40% glycol / 60% water) Solar thermal transfer fluid. Based on 1,2 - propylene glycol with corrosion inhibitors.

**DO NOT dilute or mix with water.**

Non-toxic, odourless, bio-degradable.

The use of chemical resistant gloves and suitable eye protection is required when handling.

A full safety data sheet is available on request.

Supplied in 20litre container. Weight of container full - 21kg.

### 5.3 Thermostatic Blending Valve

Can be set to control the hot water delivered to the user outlets to a safe working temperature enabling the solar cylinder to store water at a higher temperature.

Connections: 22mm compression  
Max working pressure (static): 14 bar  
Max working pressure (dynamic): 5 bar  
Min working pressure (dynamic): 0.2 bar  
Max inlet pressure ratio: 2:1  
Min flow required for stable control: 5 l/min

For pressure drop diagram and dimensions see Figs. 8 & 9

**NOTE:** For optimum operation the cold connection must be taken from a balanced cold water feed. For details of balanced cold water feed please refer to the cylinder manufacturer's instructions.

### 6.1 Safety Information

In order to reduce the number of fatalities and major accidents attributable to work at height, the Health and Safety Executive has introduced comprehensive regulations and guidance that should be followed by all businesses working at height.

We consider in the following paragraphs some of the main features of the regulations and guidance. This is, however, only a limited summary and it is recommended that all businesses planning on undertaking solar water heating installations obtain a copy of the regulations and guidance issued by the Health and Safety Executive and carefully consider the contents.

The regulations and guidance state that you are required to carry out a risk assessment for all work conducted at height and to put in place arrangements for:

- Eliminating or minimising risks from work at height.
- Safe systems of work for organising and performing work at height.
- Safe systems for selecting suitable work equipment.
- Safe systems for protecting people from the consequences of work at height.

**The regulations and guidance highlight a hierarchy for safe work at height:**

- **Avoid** the risk by not working at height if practicable.
- **Prevent** falls, where it is not reasonably practicable to avoid work at height; you are required to take suitable and sufficient steps to prevent the risk of a fall including selecting the most suitable work equipment (in accordance with the regulations).
- **Mitigate** the consequences of a fall; where the risk of a person or object falling still remains, take suitable and sufficient measures to minimise the distance and consequences of any fall.

Collective protection measures, such as guard rails on scaffold, should be given priority over personal protection measures, such as safety harnesses.

Within the regulations' framework, you are required to:

- 1) Assess the risk to help you decide how to work safely.
- 2) Follow the hierarchy for safe work at height (i.e. avoid, prevent and mitigate).
- 3) Plan and organise your work properly, taking account of weather conditions and the possibility of emergencies.
- 4) Make sure those working at height are competent.
- 5) Make use of appropriate work equipment.
- 6) Manage the risks from working on or around fragile surfaces and from falling objects.
- 7) Inspect and maintain the work equipment to be used and inspect the place where the work will be carried out (including access and egress).

When preparing to install a solar water heating system, it is required that you perform a risk assessment in relation to work at height and plan how you will organise your work, taking into account the site, the weather conditions and the experience and competence of colleagues or contractors who may be working at height with you.

### 6.2 Risk Assessments

The HSE has published a number of very useful free publications that advise how to undertake risk assessments.

Two of these that you should obtain are:  
Five Steps to Risk Assessment.  
A Guide to Risk Assessment Requirements.

**The five steps outlined in the HSE leaflet are:**

**Step 1:** Look for the hazards

This will mean looking at the site and identifying significant hazards. These could be features such as a steep roof, a fragile surface where the collectors may be mounted, uneven ground or obstructions where access to the roof might be required.

**Step 2:** Decide who may be harmed and how

This might mean considering the particular risks that young workers or trainees might face and thinking about the residents of the household or visitors who could be hurt by your activities.

**Step 3:** Evaluate the risks and decide which precautions should be made. You should consider how likely it is that each hazard will cause harm, decide which precautions you might take and then assess, after you have taken those precautions, whether the remaining risk will be high, medium or low. Where you identify remaining risks, you should consider which further action you could take to control the risks so that harm is unlikely.

**Step 4:** Record your findings

If you have fewer than five employees you do not need to write anything down, though it is useful to keep a written record of what you have done. If you employ five or more people you must record the significant findings of your assessment. You must also tell your employees about your findings. You need to be able to show that a proper check was made, that you considered who might be affected, that you dealt with all the obvious significant hazards, that the precautions you propose are reasonable and that the remaining risk is low.

**Step 5:** Review your assessment if necessary

Each solar water heating installation may bring its own challenges and present its own particular hazards. You should therefore be careful not to rely on a "standard" risk assessment for installing a solar water heating system in a house, but review the particular hazards for each new situation. The issue of work equipment must be considered, but at the preparation stage you should consider where scaffold or other access equipment might be positioned and look out for any obvious obstacles to this, such as a conservatory or porch. In addition to the risks associated with work at height, you should also consider the risks associated with lifting and carrying solar collectors, using electric drills and using blow lamps or blow torches for soldering. This is not an exclusive list and so you should consider all aspects of the proposed installation to assess whether there are additional risks that need to be taken into account.

Fig. 10

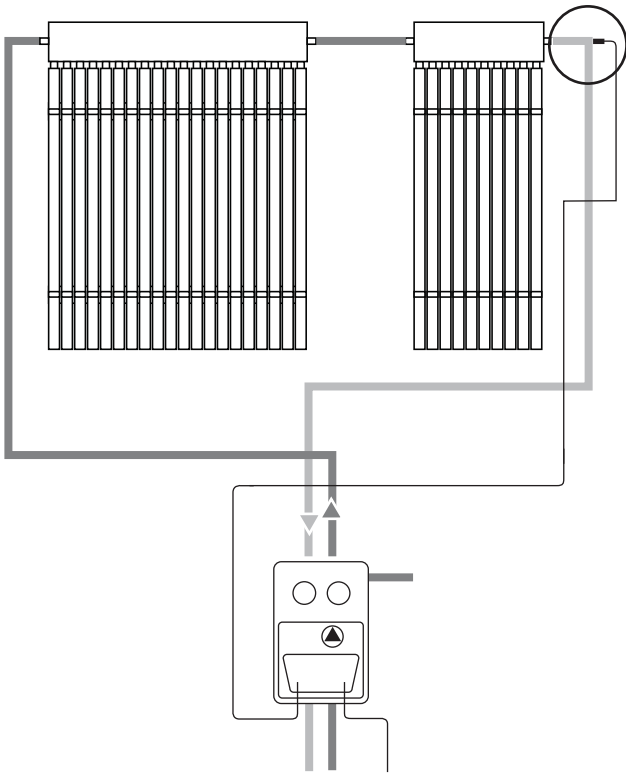

### 7.1 Installation

For the 10 tube addition, only one solar sensor is required. The solar sensor should be placed in the last sensor pocket in series. If one of the tube arrays is positioned such that more solar gain would be achieved then the sensor should be located in that manifold sensing pocket.

The Solar Collector temperature sensor should be installed in the sensor pocket securely. The sensor with the black silicone sheathing must be used in the solar collector pocket.

All materials used for installing temperature sensors (sensor element, conducting compound, cables, sealing and insulating materials) must be suitably temperature resistant (up to 200°C).

Solar Collector sensor may be extended (using the 13m extension cable supplied).

The sensor may be extended up to 50m but 0.75mm screened flex must be used.

Fig. 11

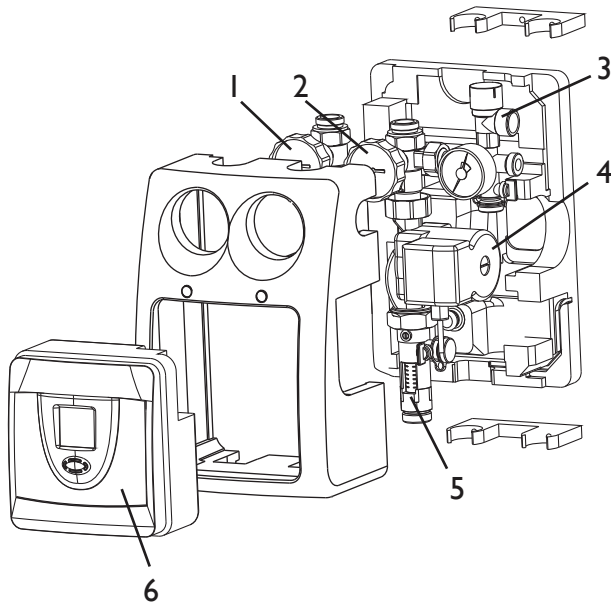

### 8.1 Identification of Components (Fig. 11)

The main components of the pump station are:

- Two isolating valves (Fig. 11, Item 1 & 2) with integral thermometers which display the solar primary flow and return temperatures.
- A safety group (Fig. 11, Item 3, supplied unconnected), which protects the solar primary circuit. The pressure relief valve and pressure gauge are integrated in the safety group.
- A non-return valve in both feed and return prevents the possibility of gravity circulation in the solar primary circuit.
- A solar circulation pump (Fig. 11, Item 4).
- A flow gauge and regulator with fill & drain valve and shut-off valve (Fig. 11, Item 5).
- An air separator.

The heat transfer fluid is circulated by the solar circulation pump integrated in the hydraulic pump station (Fig. 11).

In most instances the 20 litre container of Tyfocor LS will be sufficient quantity of transfer fluid to fill 30 metres of pipework when connected to a capacity of 30 tubes.

The pump station has a solar controller (Fig. 11 Item 6) integrated into the front insulation moulding. This is pre-wired to the solar pump.

### 8.2 Pipework installation - general

Connections supplied are suitable for pipe diameters up to 22mm. However for short pipe runs (up to 10m flow and return) the use of 15mm diameter pipe is acceptable.

The height difference between the highest point in the pipework (collector) and the pump station may be a maximum of 15m (this is called the 'static height'). If the static height is greater than 15m a larger expansion vessel may be required.

#### Earthing pipework

All solar primary pipework between the solar collectors, hydraulic station and solar cylinder must be earth bonded to avoid electrical potential differences. This work must be carried out by a qualified electrician.

Fit earthing clamps to the solar primary flow and return pipes and connect the earth clamps to the earthing system of the property using an earth bonding cable of min. 6mm<sup>2</sup> diameter.

#### Venting the pipework

The Baxi Solarflo™ hydraulic station includes an air collector/separator and bleed point so an automatic air vent is not necessary. Any section of solar pipework that falls and rises again may require an additional air vent valve to relieve any trapped air which may cause air locking in the system. The air vent must be compatible with solar primary systems, i.e. be resistant to glycol and temperatures up to 200°C.

#### Insulating the pipework

External pipework should be insulated with high temperature resistant materials and be protected against UV degradation. Internal pipework, especially through unheated spaces such as a loft space, should also be insulated with high temperature resistant materials. The Baxi Solarflo™ is supplied with 2x2m pre-insulated flexible stainless steel tubes and with additional lengths (30m) of stainless steel flexible tubes and high temperature insulation.

### 8.3 Solar Expansion Vessel

Solar expansion vessel has a pre-set pressure of 2.5 bar and must be adjusted to suit your installation.

The charge pressure at the solar expansion vessel should be adjusted such that when not under load the charge pressure is 0.7 bar above the static system head (the height of the top of the collector panels above the hydraulic station). A one metre head represents 0.1 bar. However, the charge pressure should be at least 1.5 bar.

The maximum static system head is 15m (1.5 bar).

Fig. 12

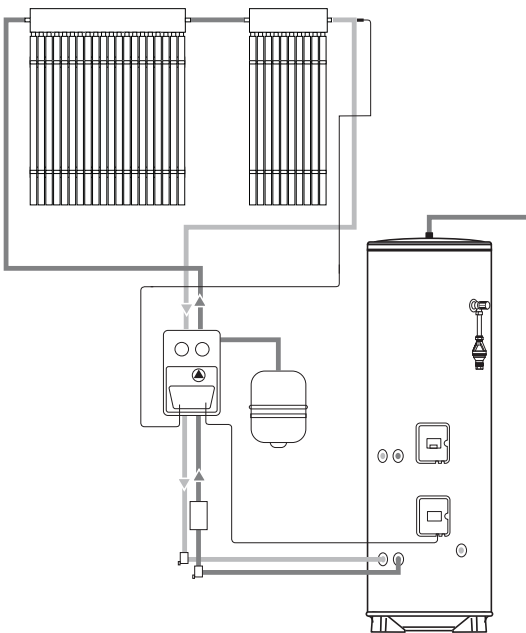

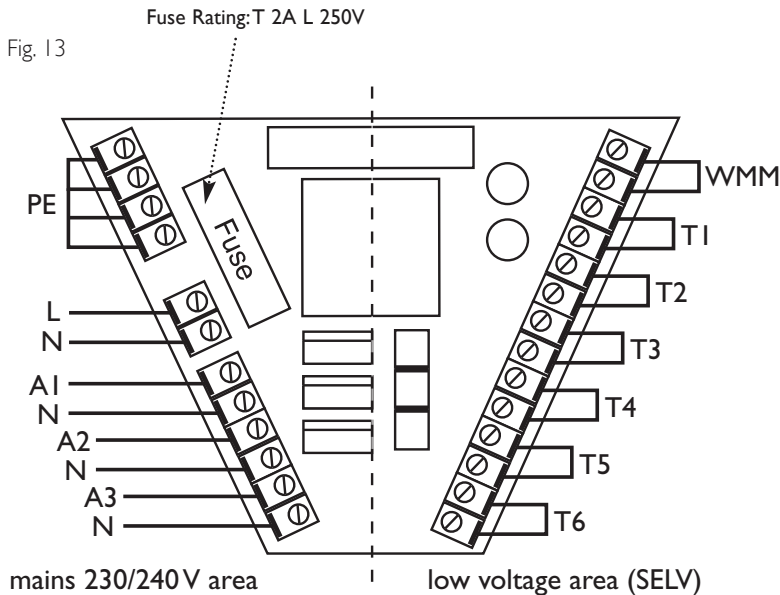

PE	Earthed connection	WMM	Flow meter
L	Mains supply live conductor	T1	Temp.- sensor collector 1
N	Mains supply neutral conductor	T2	Temp.- storage tank 1
A1	Switch output to solar pump	T3	Temp.- sensor collector 2/storage tank 2
N	Neutral wire to solar pump	T4	Temp.- sensor collector return
A2	Switch output 2 to second system pump if used (east/west)	T5	Temp.- sensor thermostat or for 2nd temperature differential controller
N	Neutral wire switch output 2	T6	Temp.- frost protection or for 2nd temperature differential controller
A3	Switch output 3 to auxiliary heating control		
N	Neutral wire switch output 3		

For switch functions A2 and A3 see Fig. 15

Fig. 14

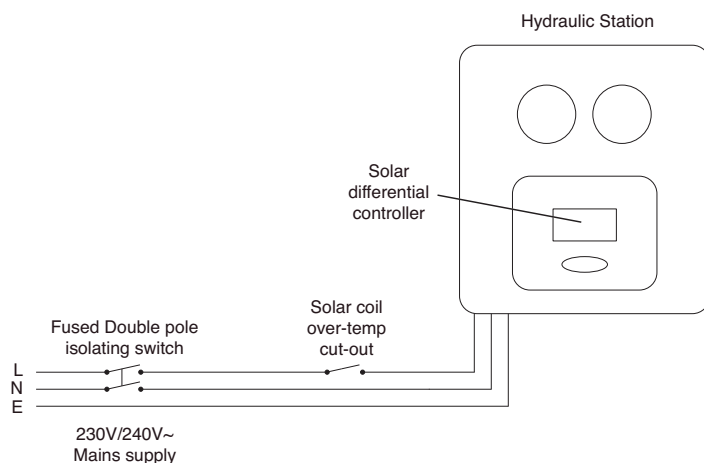

9.1 General connection guidelines.

In the case of all connecting wires the outer sheath should be stripped back to 80mm. The individual conductor sleeving should be stripped approx. 10mm.

Flexible cables are inserted in the controller through knockouts provided in the controller backplate.

Flexible cables must be secured against straining by suitable strain relief bushes or devices.

Protect flexible cables from damage by hot pipework.

The controller must be earthed.

9.2 230/240V~ connections

For 230V connections you must follow the following points:

The mains supply to the controller should be via a suitable fused double pole isolating switch with a contact separation of at least 3mm in both poles. Additionally for unvented solar cylinders the controller should be wired via the solar coil over temperature cutout such that power is interrupted to the controller and hydraulic station in the event of the unvented cylinder overheating (see Fig. 14).

Controllers are intended for the operation in 230/240V~ /50Hz mains. Any motorised valves connected must be suitable for this voltage.

All earth wires must be connected to terminals marked with PE. Any bare wire earth conductors must be sleeved with green/yellow sleeving.

The neutral terminals (N) are electrically connected and are not switched.

All switch outputs (A1, A2 and A3) are 230/240V~ 1 Amp max load outputs. If voltage free contacts are required, this must be done via a relay (see Figs. 16 or 17 Block Wiring Scheme C or E) order accessory Code No. 5122765.

**NOTE:** The Solar Differential Controller's internal 1A switch outputs are not suitable for Y plan systems.

**NOTE:** This controller is suitable for S plan and Y plan systems. However, in the event of an installation having a 'Y' plan boiler system that is to be controlled by the solar controller, a relay is required (not supplied). This is available as a Baxi Spares Item, Code No. 5122765.

Fig. 15

**Type 0:**  
1 collector, 1 storage tank

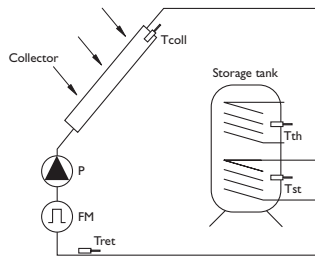

**Type 2:**  
1 collector, 2 storage tanks  
with 2 pumps

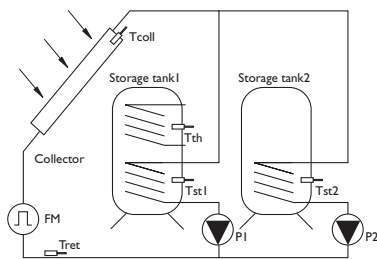

**Type 4:**  
2 collectors, 1 storage tank  
with 2 pumps

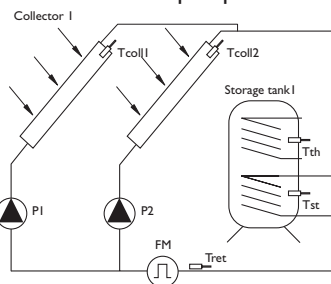

## 9.0 Installation of solar controller

### 9.3 Solar Gain measurement

For solar gain measurement it is necessary to fit the flowmeter and collector return sensor (Tret) as shown in the diagram in Fig. 15. The collector return sensor must be securely attached to the return pipework using the securing ties supplied and then covered by insulation. The solar gain of the system is calculated on the basis of the temperature difference between the collector flow and return and the solar primary circulation flow rate.

**The function must be switched "on" when commissioning the Solar Controller.** Refer to the Baxi Solarflo™ "Commissioning, Maintenance & Servicing Guide" for further details.

For System Types 2 and 4 the additional pump (P2) can be ordered as an accessory, Part No. 5129362

Tcoll	Temperature measuring point collector
Tth	Temperature measuring point thermostat auxiliary sensor
Tret	Temperature measuring point collector return
Tst	Temperature measuring point storage tank
P	Pump
FM	Flowmeter

System type		Output terminal designation (see Fig. 13)		
Type	Description	A1	A2	A3
0	1 collector array, 1 storage cylinder	P1	-	Auxiliary heating
2	1 collector array, 2 storage cylinder (pump-pump)	P1	P2	
4	2 collector array, 1 storage cylinder (pump-pump)	P1	P2	

System type		Sensor terminal designation (see Fig. 13)					
Type	Description	T1	T2	T3	T4	T5	T6
0	1 collector array, 1 storage cylinder	Tcoll1	Tst1	-	Tret	Tth	
2	1 collector array, 2 storage cylinder (pump-pump)	Tcoll1	Tst1	Tst2	Tret	Tth	
4	2 collector array, 1 storage cylinder (pump-pump)	Tcoll1	Tst1	Tcoll2	Tret	Tth	

NOTE: The solar gain flowmeter must be connected to sensor terminals marked WMM (see Fig. 13).

Fig. 16

NOTE: Arrows identify wires which go to wiring centre terminal block.

### Block Wiring Schemes

A. Baxi Solarflo™ in conjunction with auxiliary heating by boiler - no reheat control by solar controller.

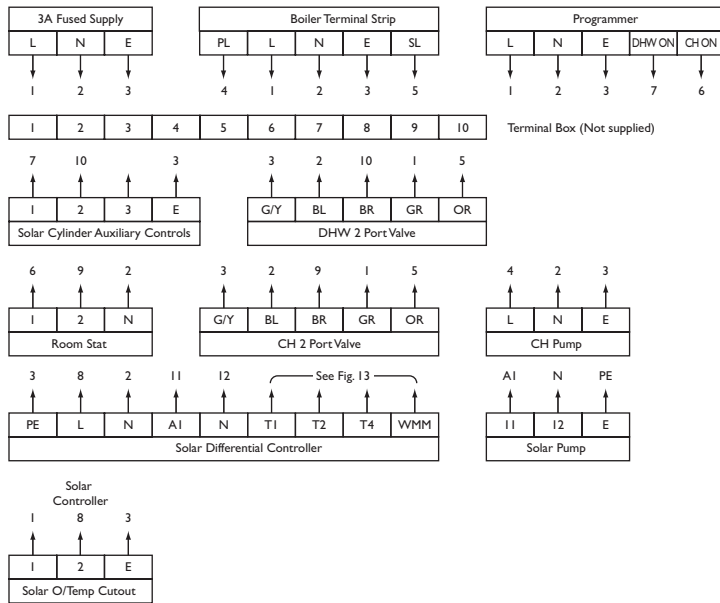

**Note:** If boiler has PL - Pump Live connection, pump must be connected to this (4), if not Pump Live should be connected to SL (5).

B. Solarflo in conjunction with auxiliary heating by boiler - reheat control via solar controller.

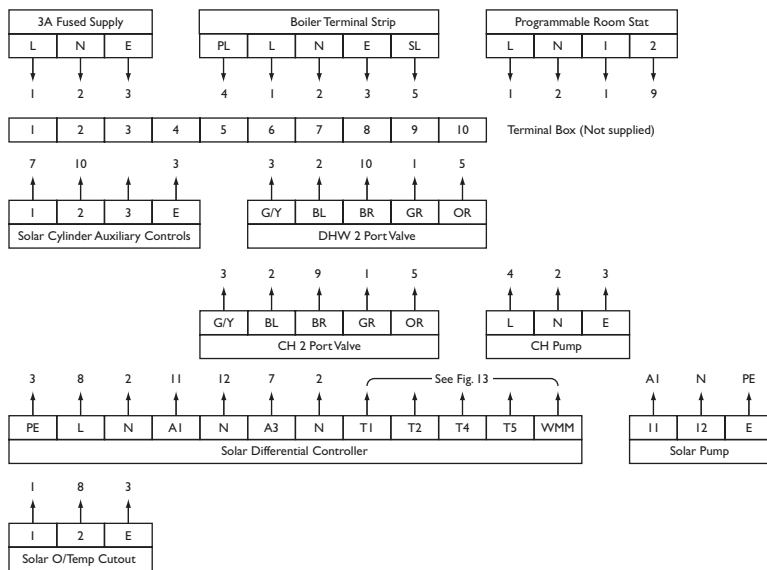

C. Solar Cylinder with auxiliary heating by immersion heater.

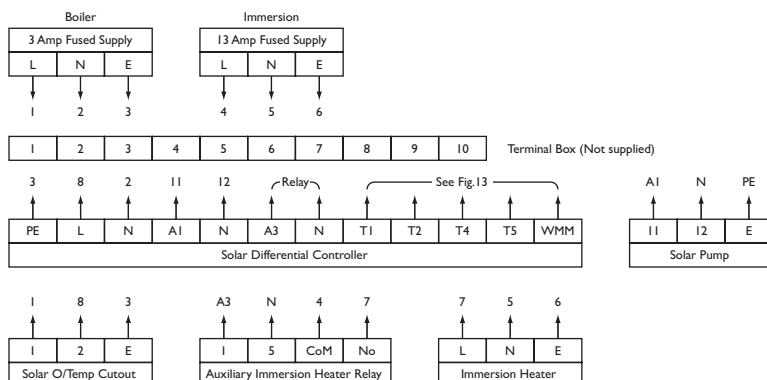

## 9.0 Installation of solar controller

### 9.4 Connection of temperature sensors

The sensor with black silicone sheathing must be used for the solar collector sensor.

The controller uses precise platinum temperature sensors type PT1000. The controller is supplied with 3 sensors.

#### Installation / cabling of temperature sensors:

Mount the sensors in the pockets provided in the collector and storage tank.

The wires of the temperature sensors can be lengthened. Up to 15m long you need a 2 x 0,5mm<sup>2</sup> cross-section, up to 50m 2 x 0,75mm<sup>2</sup>. In the case of long connections (collector) shielded extension lead must be used.

**DO NOT** run sensor leads adjacent to mains carrying voltage conductors (at least 50mm separation is recommended).

Temperature sensors are connected according to the appropriate terminals, refer to Fig 13.

The sensors are polarity free.

Sensors **MUST NOT** be connected to the 230/240V~ terminals.

### 9.5 Control of Auxiliary heat input

When using the reheat function the operation of the auxiliary heat input device can be controlled via output A3 from the controller.

The reheat sensor cable should be connected to terminal T5 of the solar controller and the sensor element inserted into the controls pocket at the auxiliary heater level.

**NOTE:** The maximum switching current of the controller is 2 Amp in total, 1 Amp per output. If switching an electrical immersion heater or using a 3 port valve system this **MUST be done via a relay** (see Figs. 16 or 17 Block Wiring Scheme C or E) order accessory code No. 5122765.

If using a boiler for auxiliary input, the output from the reheat function should be integrated into the boiler control circuit.

Fig. 17

## 9.0 Installation of solar controller

### D. Auxiliary heating by boiler with 3 port mid position valve system - no reheat control by solar controller.

**NOTE: Must use 2 port safety valve supplied with cylinder**

Key to abbreviations:

L	-	Live
N	-	Neutral
E	-	Earth
PL	-	Pump Live
SL	-	Switched Live
G/Y	-	Green and Yellow
BL	-	Blue
BR	-	Brown
GR	-	Grey
OR	-	Orange
WH	-	White

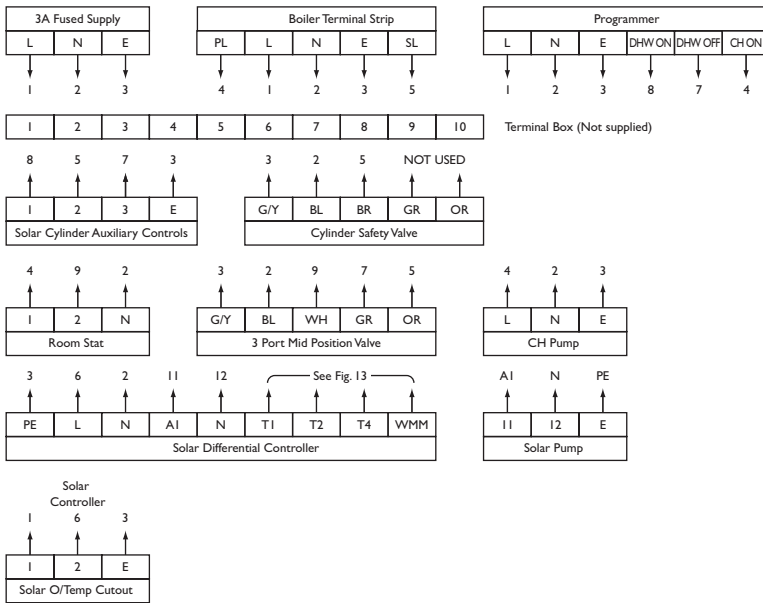

The wiring schemes assume the use of an unvented Solar DHW cylinder.

**NOTE:** For open vented cylinders 1 to 6 connection is required in the wiring centre.

These diagrams are presented for guidance only, terminal numbers may differ between different manufacturers equipment.

### E. Auxiliary heating by boiler with 3 port mid position valve system - reheat control by solar controller.

**NOTE: Must use 2 port safety valve supplied with cylinder**

The various ancillary equipment manufacturers should be consulted to confirm the correct operation of their products within the system.

The Warranty only applies to equipment and controls supplied with the Solarflo System.

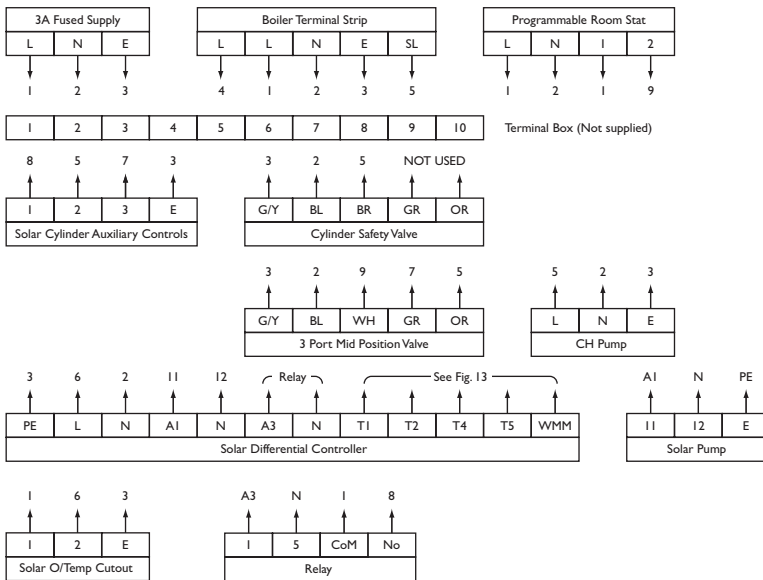

### 10.1 General assembly notes

These instructions relate to the installation of the Baxi Solarflo™ Evacuated Tube Collector Pitched Roof Mounting. Parts are provided for fixing to slate or tile roofs. Refer to the parts list to ensure the correct components are in the pack. All other equipment must be installed as detailed in the Baxi Solarflo™ Installation Guide.

Use only Baxi Solarflo™ mounting systems. Use of other brackets/mounting systems will invalidate the warranty and may result in an insecure and dangerous evacuated tube collector installation.

The mounting brackets must be fixed to the roof structural members. They must never be fixed to roofing laths. If suitably positioned structural members are not available or, if they are of a section that may be weakened by the inserting of the fixing screws, additional noggins should be inserted between the structural members. These must be at least the same cross section as the structural member.

Use only the corrosion resistant fastenings supplied. Holes through any roof waterproofing materials should be sealed with an appropriate UV and weather resistant sealant.

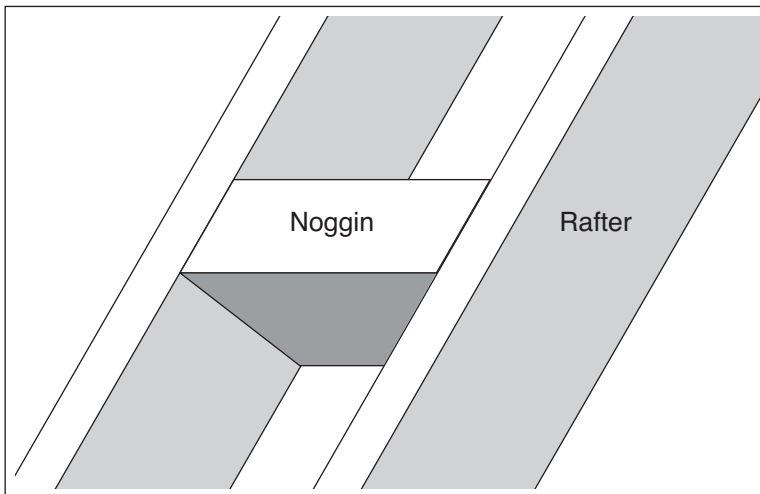

Fig. 18

### 10.2 Structure

The collectors may only be mounted on sufficiently load-bearing roof surfaces and substructures. It is essential that the structural load-bearing capacity of the roof and the substructure must be assessed before mounting the collectors. Particular attention should be paid to the quality of the (timber) substructure in terms of the stability of the screw joints necessary for installing the collector mounting brackets. Where roof structure is not strong enough noggins must be inserted to accept anchor screws. The roof structure must be able to take the wind and snow loads that can occur. The assessment should also take into account any special features of the particular site that could lead to increased loads (air jets or eddy formations, etc).

### 10.3 Lightning protection / Equipotential bonding of the building

It is not necessary to connect collector arrays to the lightning protection of the building. For installations on metal substructures at the installation site, authorised lightning protection specialists must be consulted. The metal pipes of the solar circuit must be earth bonded to the main earthing circuit by means of a conductor (green/yellow) with a cross-section of at least 6mm<sup>2</sup>.

### 10.4 Connections

Ensure the sealing washer provided is inserted between the male and female connections. All connecting pipe work and fittings must be of a suitable metal; either copper, brass or stainless steel. Soft soldered joints must not be used. Any seals or sealing compounds must be resistant to temperatures of up to 200°C and be resistant up to a 50% glycol/water mix.

When tightening the connections, always apply counter-pressure with a wrench or another spanner to prevent damage.

### 10.5 Collector inclination for Pitched Roof Mounting

The collector is suitable for angles between 0 - 90°. The roof aspect should ideally face South, however orientations between 30° East and 40° West of South are acceptable. Fig. 19 shows the efficiency loss for varying angles of inclinations and roof orientation (Portrait & Landscape).

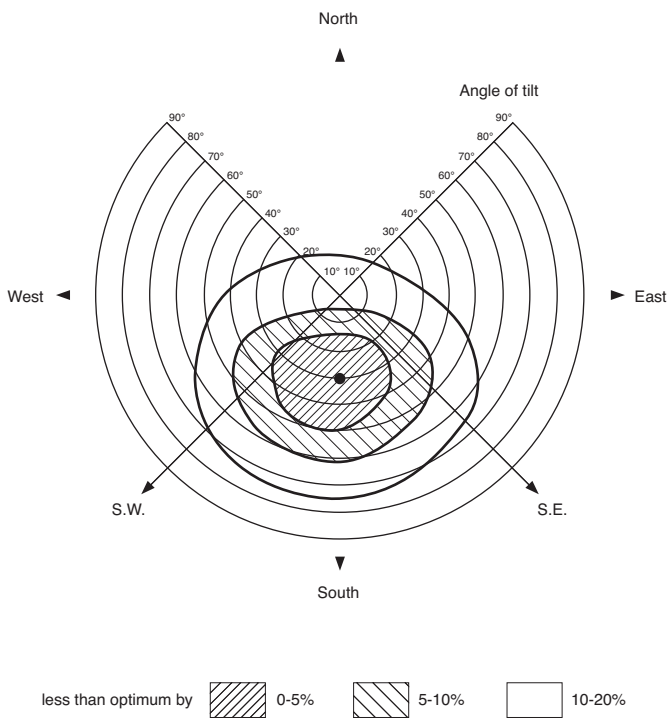

Fig. 19

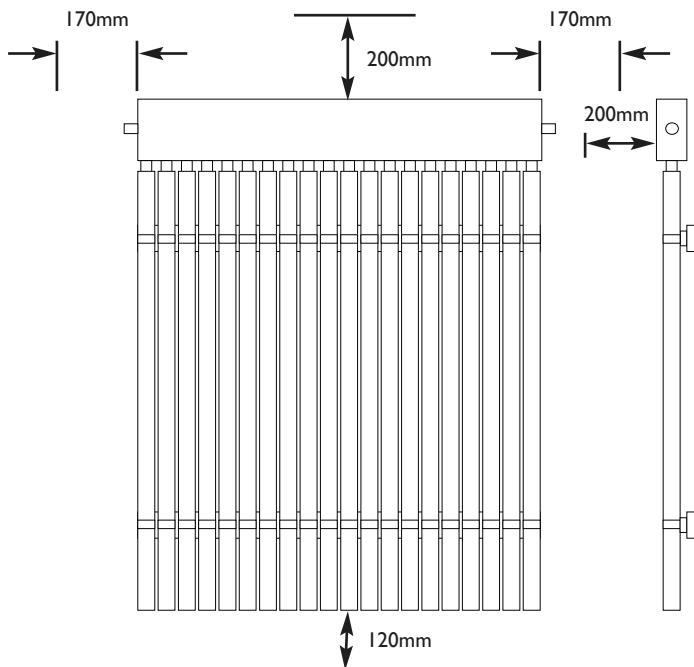

Fig. 20

### 10.6 Solar fluid

The Baxi Solarflo™ collector tubes MUST be protected with the supplied fluid. **Top-ups cannot be made with water**, only use the fluid supplied (Tyfocor LS). Systems found to have lower glycol concentrations will not be covered by the warranty.

### 10.7 Collector location

Under no circumstances should the collector be fitted where it overhangs any part of the roof structure.

Minimum clearances must also be adhered to for servicing and or replacement of parts (see Fig. 20).

## 11.0 Installation of solar collector

### 11.1 Collector Orientation

The pitched roof mounted collector may be orientated portrait or landscape to suit installation. Assess the location for installation and determine which orientation is required.

### 11.2 Assembly of Kit

Prior to installation check that the following packs are available

		Manufacturer's Part No
Manifold Pack	20 tubes	5130220
	10 tubes	
Sloping Roof Fixing Pack		5130223
Tube Box (10 off)		5130222
(ensure enough boxes for installation)		
Connection Kit		5130224

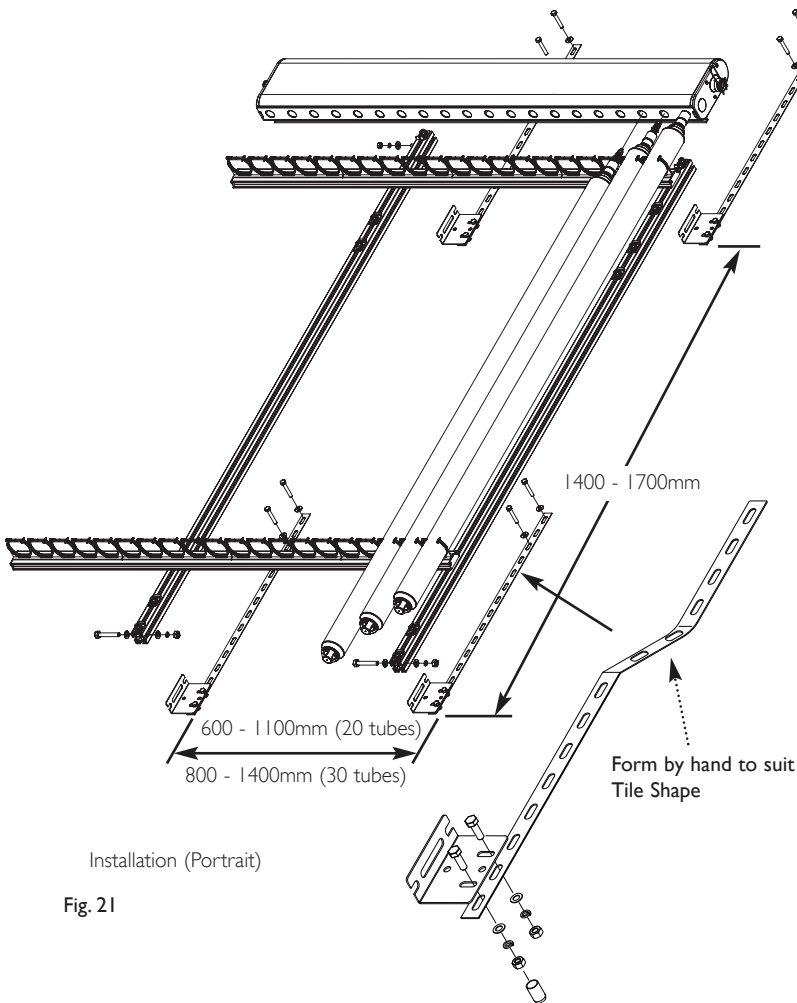

Installation (Portrait)

Fig. 21

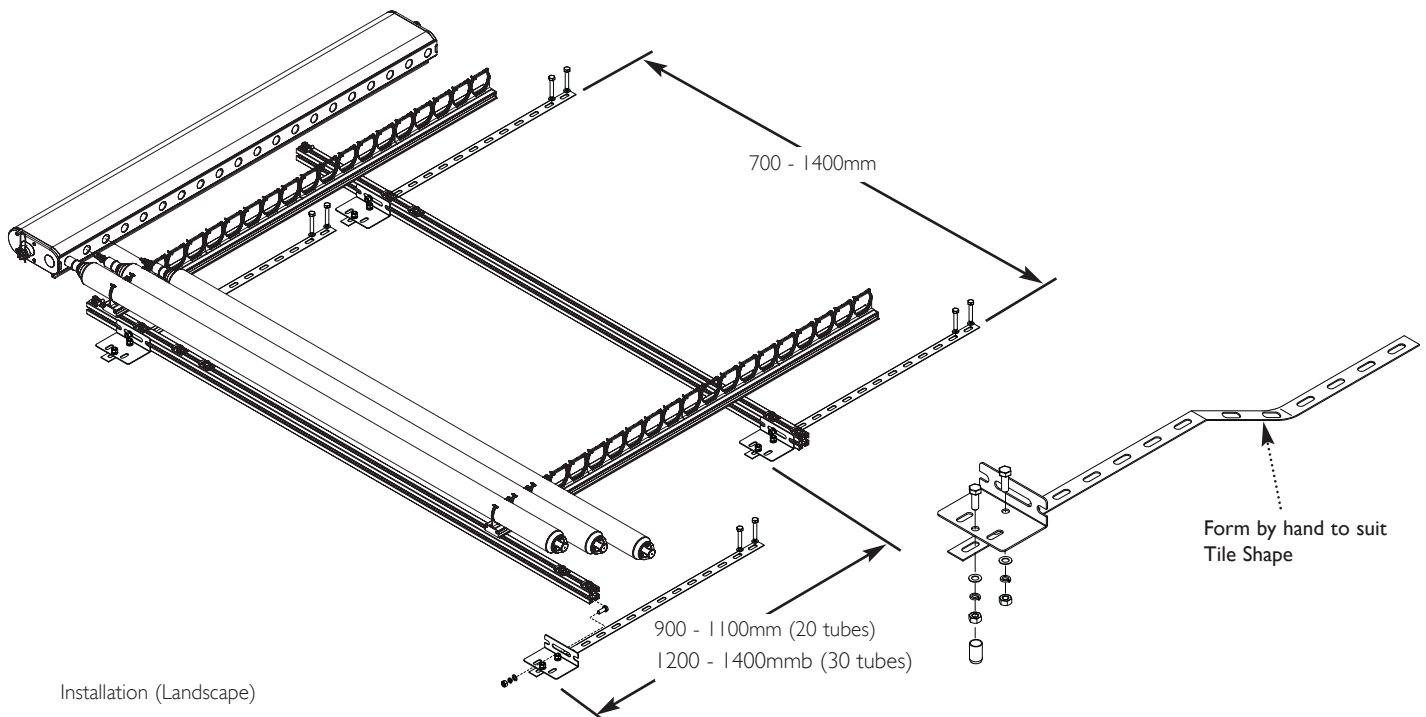

Installation (Landscape)

Fig. 22

## 11.3 Bracket Fixing

Prior to fixing the mounting brackets to the roof structure, adjust the assembly for your selected installation, portrait or landscape.

1. Remove the rubber cover.
2. Untighten the two nuts which secure the angle bracket (Fig. 23).
3. Adjust the angle bracket to the correct orientation (portrait or landscape) for the installation (Figs. 23 & 24).
4. Resecure with the bolts and nuts.
5. Refit the rubber cover.

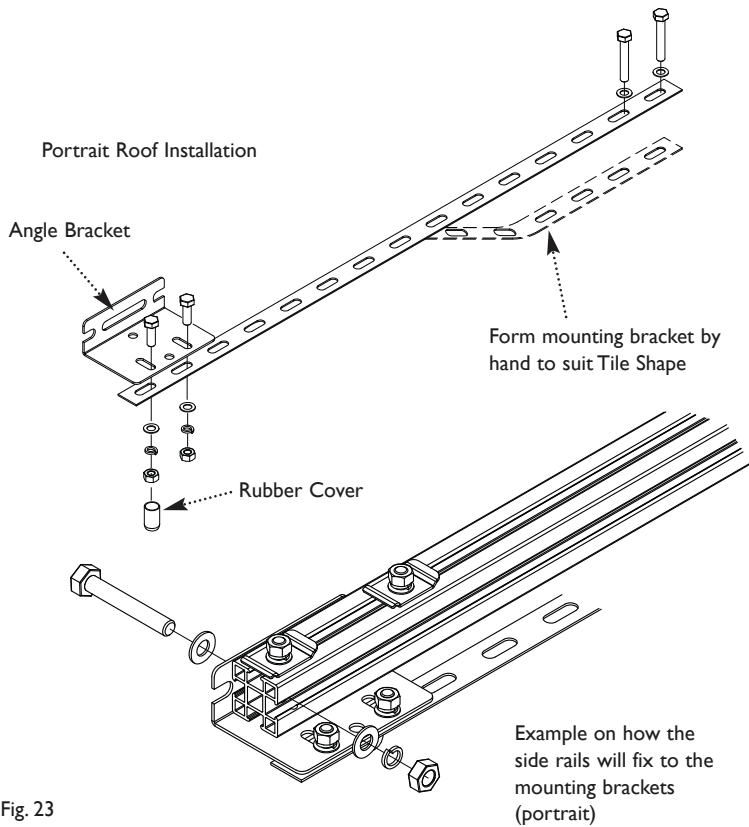

Fig. 23

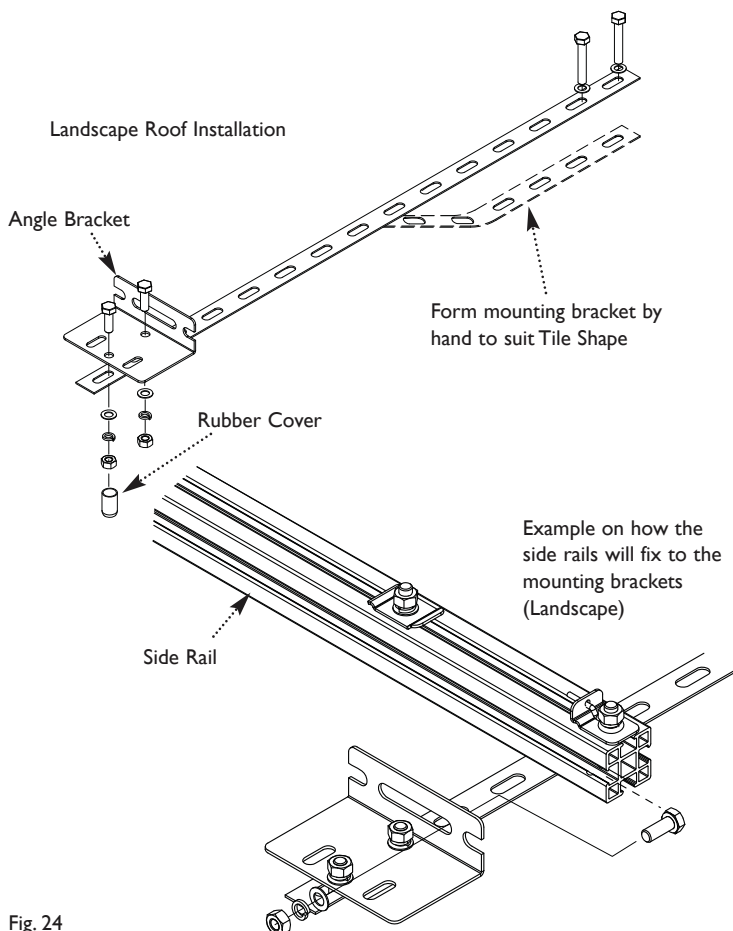

Fig. 24

### 11.4 Sloping Roof Kit (Portrait/Landscape)

**NOTE:** The application for fixing the lower and upper mounting brackets are the same.

1. Determine location for lower mounting brackets. Remove sufficient tiles to give access for fixing the mounting brackets to the roof structure. Additional noggins may be required (Figs. 18 & 26).

2. Attach lower mounting brackets to roof ensuring the correct centres and alignment to roof aspect for your orientation is used (portrait or landscape) (Fig. 25).

3. The mounting brackets are designed to be formed by hand to the shape of your tiles/slates. Form the mounting brackets to the correct shape (Figs. 25 and 26).

4. Replace roof tiles/slates.

5. Secure side rails to lower mounting bracket.

6. Determine location for upper mounting brackets. Remove sufficient tiles to give access for fixing the mounting brackets to the roof structure. Additional noggins may be required (Figs. 18 & 26).

7. Attach upper mounting brackets to roof ensuring the correct centres and alignment to roof aspect for your orientation is used (portrait or landscape) (Fig. 25).

8. The mounting brackets are designed to be formed by hand to the shape of your tiles/slates. Form the mounting brackets to the correct shape (Figs. 25 & 26).

9. Replace roof tiles/slates.

10. Secure side rails to upper mounting brackets.

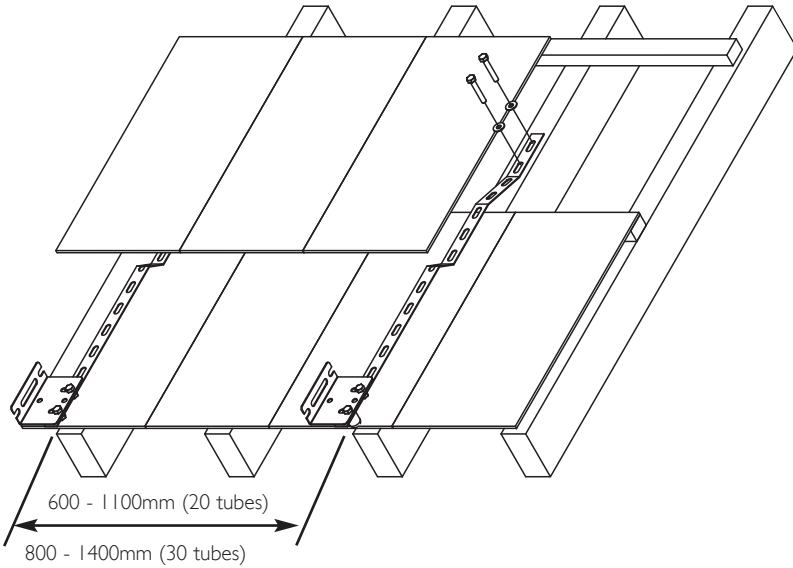

See Fig. 22 for Landscape Orientation Dimensions

Fig. 25

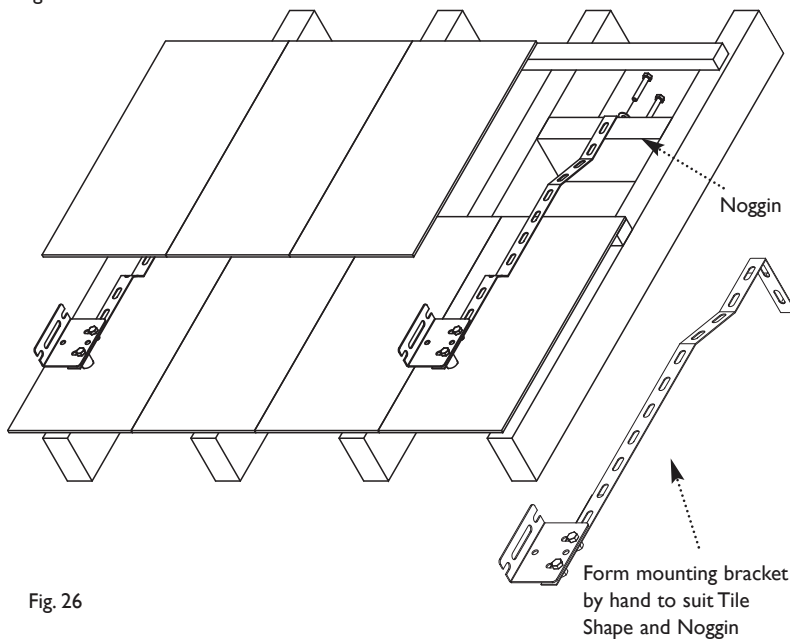

Fig. 26

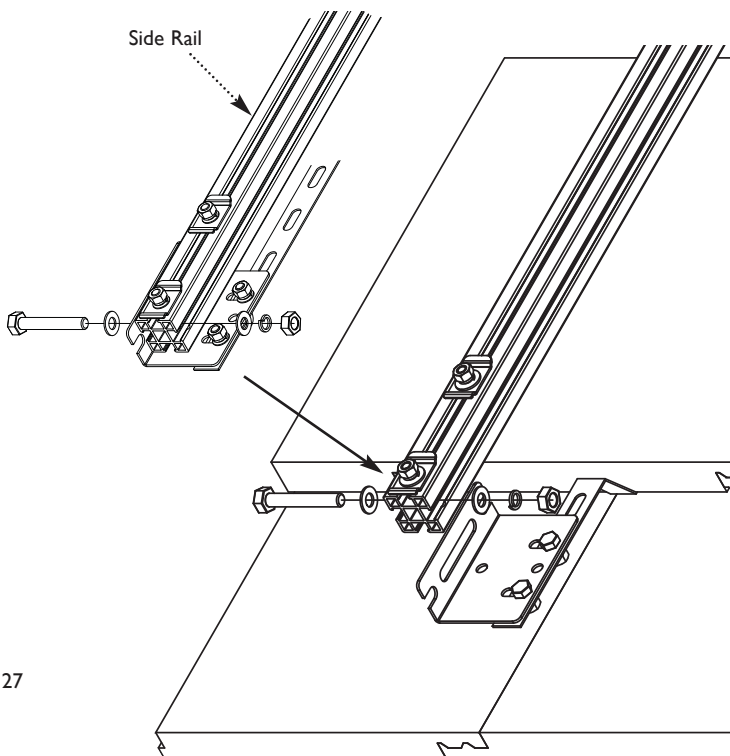

Fig. 27

## 11.4 Sloping Roof Kit (Portrait/Landscape) (cont)

**NOTE:** All side rails are supplied ready for portrait mounting. For landscape mounting the locking pins must be fitted (Fig.29).

- a) Untighten the top clamp nut and remove.
- b) Remove spring washer and flat washer.
- c) Fit locking pin.
- d) Refit spring washer and nut.

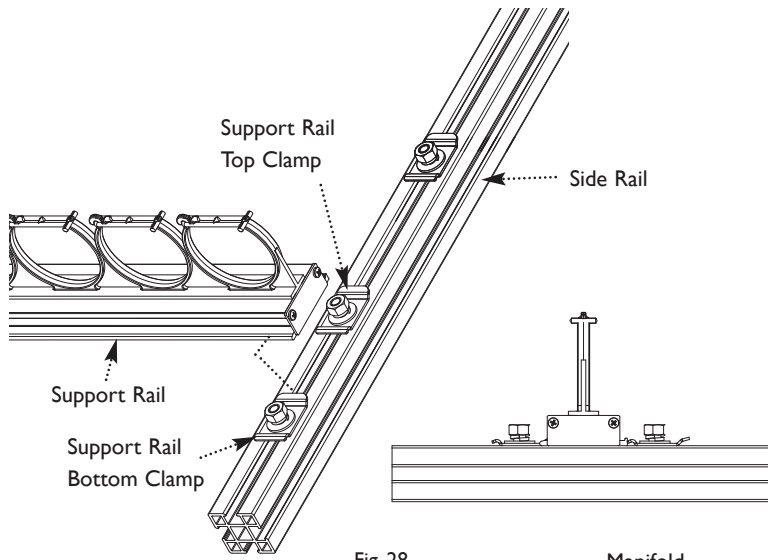

Fig. 28

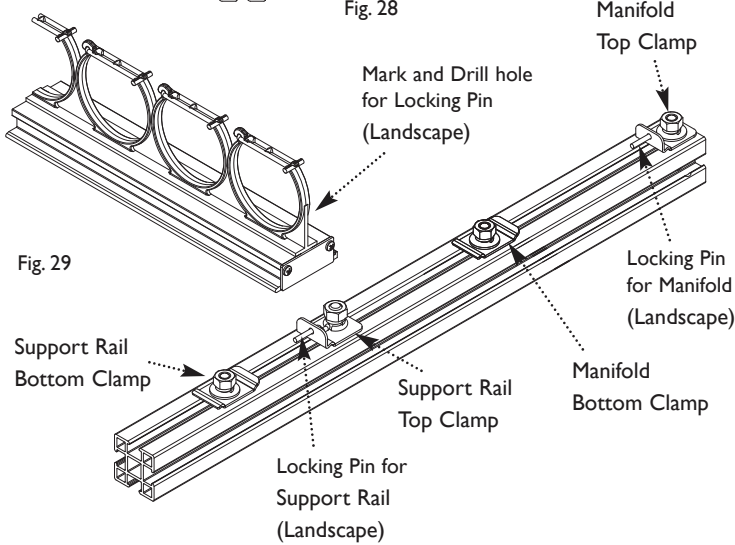

Fig. 29

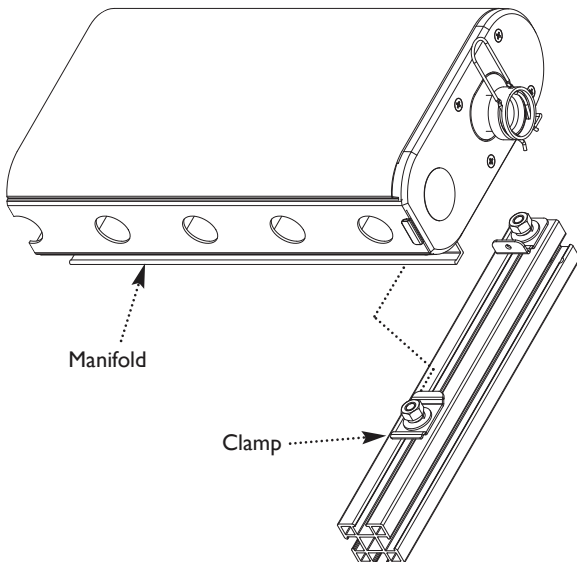
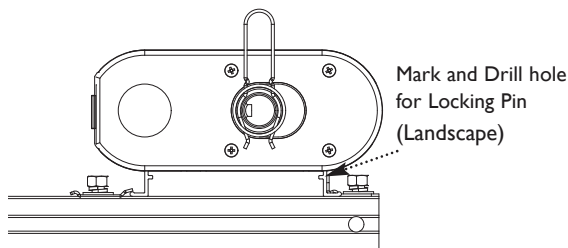

Fig. 30



11. Loosen the lower support rail top clamps and slide away from the support rail bottom clamp.

12. Locate the lower support rail and centralise on the side rails. Slide the top clamp over the support rail to retain (Fig. 28).

13. For landscape installations, mark the position for the locking pin holes on the support rail. Drill holes 3mm diameter in the correct location. Fit the locking pins and ensure full engagement into the drilled holes (Fig. 29).

14. Tighten the top clamps fully and check the support rail is secure.

15. Repeat 11 to 14 for the upper support rail.

16. Loosen the manifold top clamps and slide away from the manifold bottom clamp (Fig. 30).

17. Locate the manifold and centralise on the side rails and slide the top clamp over the manifold to retain (Fig. 30).

18. For landscape installations mark position for the locking pin holes on the manifold. Drill holes 3mm diameter in the correct location. Fit the locking pins and ensure full engagement into the drilled holes (Figs. 29 & 30).

19. Tighten the top clamps fully and check the manifold is secure.

### 11.5 Fitting the Tubes

1. Open manifold lid by removing front seal strip.
2. Open the tube retaining rubbers on the tube clip and place the tube in the tube clips on both supports rails (Fig. 31).
3. Slide tube into manifold connection while slightly rotating tube until washer on below sits flush against manifold fitting. Do not apply force, if any problems check alignment of support rails to manifold.
4. Insert tube retaining clip to secure tube to manifold (Fig. 32).
5. Gently pull on tube to ensure a secure assembly.
6. Close tube retaining rubber on both support rails. Repeat steps 2 to 6 for all tubes.
7. Close manifold lid ensuring proper engagement of front seal strip over whole length and on end caps.

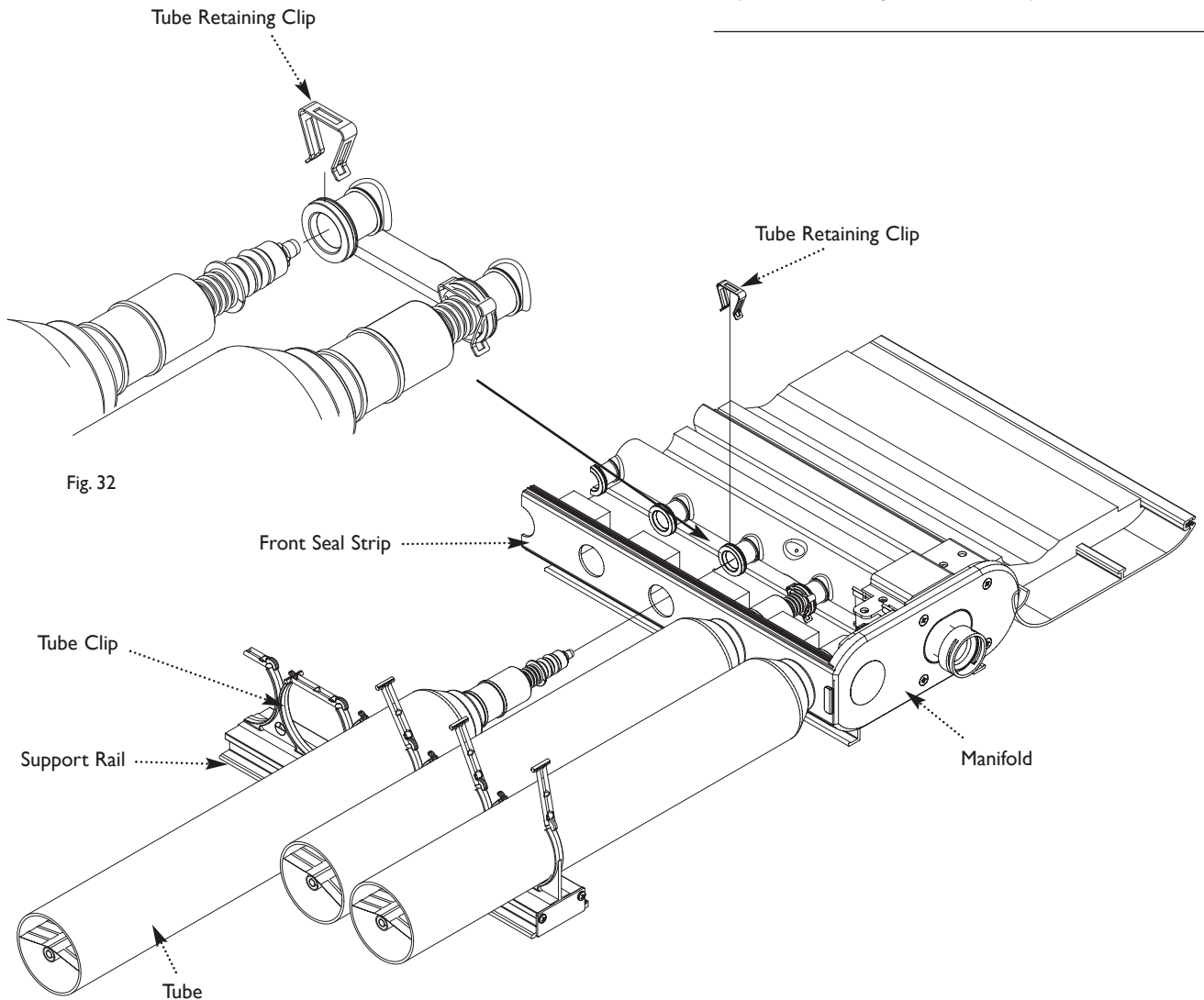

Fig. 32

Fig. 31

### 11.6 Fitting the Connection Kit (Fig. 32)

1. Do not remove pipe clip.
2. Ensure clip is in the position shown.
3. Insert brass adaptor fully.
4. Push pipe clip in fully and check that the brass adaptor is correctly retained..
5. Fit the sensor pocket to the compression elbow.
6. Fit compression elbow with sensor pocket and tighten the union nut.
7. Fit the copper tail ensuring the pipe clip is in the open position.
8. Push pipe clip in fully and check that the copper tail is correctly retained.
9. Fit the air bleed fitting to the compression elbow.
10. Fit compression elbow and tighten the union nut.

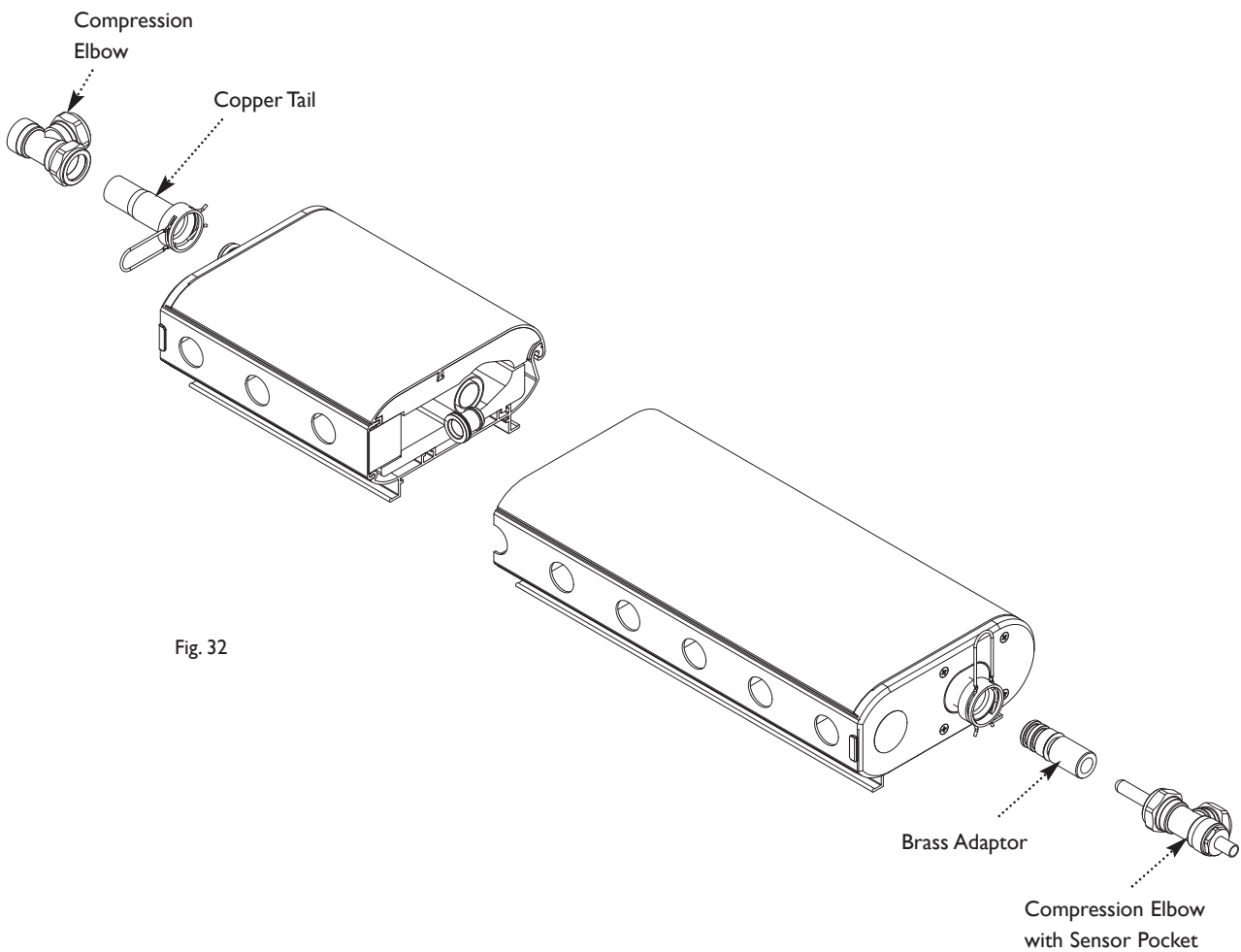
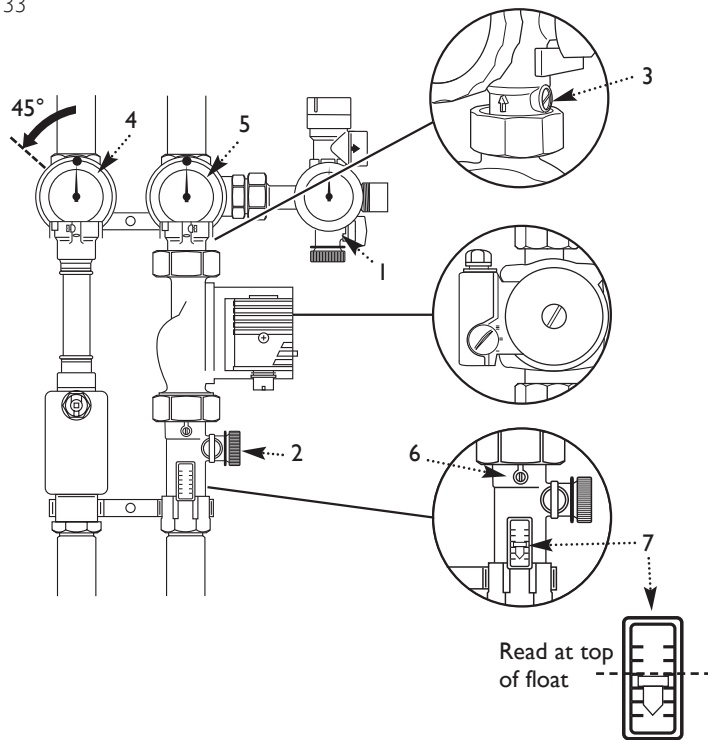

Fig. 32

Fig. 33



## 12.0 Commissioning of system

If commissioning the 10 tube array is part of existing solar upgrade, the following instruction should be observed.

### 12.1 Draining Down of the System

Before attempting to drain down the system, it is essential to ensure the temperature of the transfer fluid is at a safe level. The fluid should be at room temperature and the collectors covered prior to the commencing of work.

- a) The PRV drain should already be placed in a container:
- b) Open PRV to discharge system pressure.
- c) Connect a filling pump to the fill and drain valves on the solar pump station.
- d) Turn the right hand combined pressure gauge (Fig. 33 Item 5) through to 45°. Turn the flow meter adjustment screw to 9 o'clock (Fig. 33 Item 6) and turn the non return valve screw to 9 o'clock.
- e) Open the isolation valves (Fig. 33 Items 1 & 3).
- f) Approximately 5 litres of transfer fluid should be drained from the system to ensure that during any pipework modifications to add a 10 tube array no fluid inadvertently spilled.
- g) Consideration should be made to the condition of the solar fluid and it should be changed completely if tested and found to be degraded. A Baxi test kit (Part No. 5119559) is available for this purpose.
- h) A 2 metre pipe kit (Part No. 5131036) is supplied with the 10 tube addition, this should be sufficient in length to make connections between both manifolds during a new installation due to the fact that 30 metres are supplied with the main kit, however if the 10 tube manifold is fitted retrospectively, further solar tubing may be required, available as: 30 solar tubing accessory (Part No. 5122238).

### 12.2 Air Test

1. An air test may be used on the pipework to detect any gross leakage prior to flushing and filling with solar heat transfer fluid. Pressurise the system to a maximum of 1 bar to check for leaks.
2. Ensure that the solar expansion vessel pre-charge pressure has been set prior to flushing and filling. See Installation Instructions Section 9.8 for details.

### 12.3 Flushing and Filling the pipework

Fig. 34

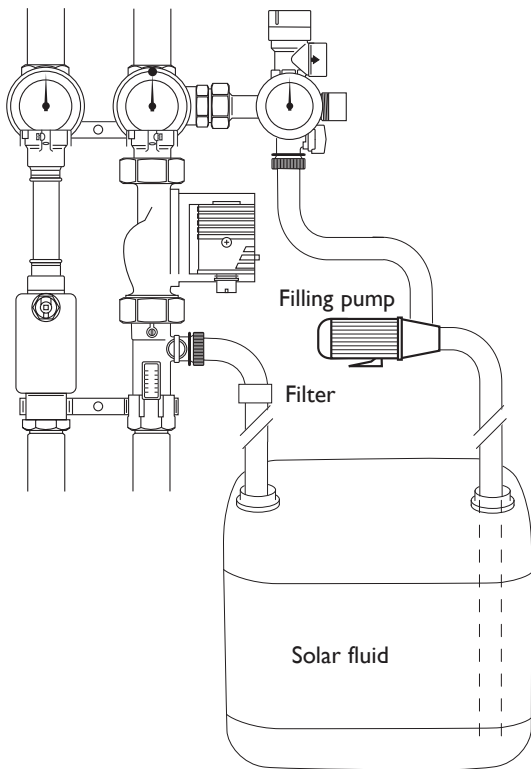
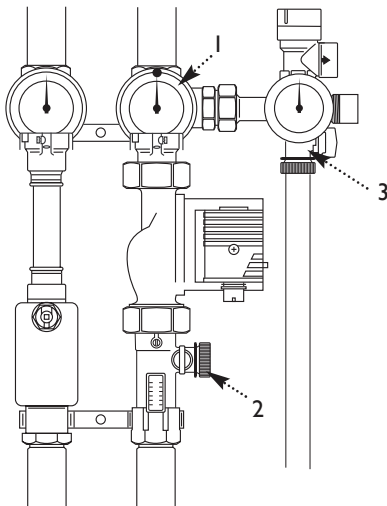

Fig. 35



1. Before the system is commissioned the pipework must be flushed to remove any contaminants. **This must be done using the solar heat transfer fluid as it will be impossible to fully drain all parts of the system.**

2. Connect the flushing pipes to the fill & drain valve on the safety group (Fig. 33 Item 1) and to the fill & drain valve on the flow meter (Fig. 33 Item 2).

3. Open the fill & drain valves.

4. Turn the slot of the adjusting screw (Fig. 33 Item 3) in the return so the slot is vertical to open the non-return valve.

5. Turn the left hand isolating valve with integral thermometer in the flow (Fig. 33 Item 4) in the direction indicated by the arrow (to a 45° position) to open the non-return valve.

6. Ensure that the right hand isolating valve with integral thermometer in the return (Fig. 33 Item 5) is open indicated by the dot on the thermometer bezel being at the top.

7. Turn the slot of the flow meter adjusting screw (Fig. 33 Item 6) in the return vertically to open the flow limiter (Fig. 33 Item 7).

8. Flush the solar primary pump by pumping the fluid into the system via the fill and drain valve on the safety group (Fig. 33 Item 1).

9. Close right hand isolating valve (dot on thermometer bezel at 9 o'clock position). Flush solar primary pipework and collector via the fill and drain valve on the safety group. **If reusing flushed fluid ensure this is filtered before re-introducing into the system.** (see Fig. 34). Use a suitable container of a large enough volume to collect the fluid.

10. When satisfied that all pipework and component parts have been thoroughly flushed, the system can be filled.

11. Pour an amount of the solar heat transfer fluid into the filling pump.

12. Close the fill and drain valve - safety group (Fig. 33 Item 1) and the fill and drain valve - flow meter (Fig. 33 Item 2) and pressurise the pump slightly prior to filling the system. If an electric pump is being used follow the instructions with the pump.

13. Fully open the fill and drain valve on the safety group (Fig. 33 item 1) and pump fluid into the system. Whilst pumping, open the flow meter drain valve (Fig. 33 item 2) slightly to allow the air to vent out of the system.

14. When the pump is down to approximately 1 litre isolate the fill and drain valves. Vent the filling pump and refill with solar heat transfer fluid.

15. Re-pressurise the filling pump and repeat steps 3 and 4 above until fluid is seen discharging from the drain valve on the flow meter. (Fig. 33 item 2). Close the drain valve.

16. Continue filling at the fill and drain valve on the safety group (Fig. 33 item 1) until the system pressure reaches 2 bar.

17. At this point the pump should be vented. If the system pressure drops, repressurise using the procedure above.

18. After venting the pump and checking that the system pressure is 2 bar, close the fill and drain valve on the safety group (Fig. 33 Item 1).

### 12.3 Flushing and Filling the pipework (cont)

19. Turn the left hand isolating valve (Fig 33 item 4) back 45° clockwise until the dot on the bezel is back at 12 o'clock.

20. Turn the right hand isolating valve (Fig. 33 item 5) back 90° clockwise until the dot on the bezel is back at 12:00 O'clock.

21. Turn on the power to the solar controller. This should display the information screen (See Section 14.1 Main Menu).

22. Key the left button once to enter the main menu screen. The 'i' icon will flash (See Sections 14.1 Main Menu and 14.2 Control Button for display and button function).

23. Press the right button twice to select the manual operation menu. Press the down button and the 'pump' symbol and the 'switch output 1' symbols should now be seen with a 'zero' displayed. Changing the 'zero' to a 'one' will operate the pump. To do this, press the right button and the 'zero' will flash.

24. Press either the up or down button to manually activate the pump, then key right to accept the setting.

25. Leave the pump running for sufficient time to allow any residual air to be purged from the system via the air separator and any bleed points fitted to the system. Use the flow meter window as a visible indicator of the air bubbles. The reading should be stable. **NOTE: During this time the system may be checked for leaks.**

26. Stop the pump using the button procedure described above. If pressure has been lost from the system during the air bleeding process, repressurise as follows:

#### 27. Repressurise the Filling Pump

- Open the adjusting screw (Fig. 33 item 3) to vertical.
- Set the left hand isolating valve (Fig. 33 item 4) to 45° and the right hand isolating valve (Fig. 33 item 5) to 9:00 O'clock.
- Open the fill and drain valve - safety group (Fig. 33 item 1) and repressurise the system to 2 bar.
- Close the fill and drain valve - safety group (Fig. 33 item 1).
- Return the left hand and right hand isolating valves to 12:00 O'clock.
- Close the adjusting screw to horizontal.

#### 28. Setting the System Pressure

- During commissioning, the system pressure should be 0.7 bar above the static pressure (1 metre height differential equals 0.1 bar). However, it must be at least 1.5 bar and no higher than 2.2 bar.
- Determine the system pressure when the system is cold (20°C). This should be recorded on the Commissioning Record Sheet (section 15.0).
- If the pressure is too low you should pump additional heat transfer fluid into the system; the fill & drain valve on the safety group (Fig. 36 Item 2) needs to be opened for this purpose. When system pressure is correctly set, ensure the fill and drain valve is closed and remove filling hose from safety group.

29. Remove all tubing from the fill and drain valve on the safety group (Fig 33 item 1) and the drain valve on the flow meter: (Fig 33 item 2) and replace both the sealing caps securely, ensuring that the rubber seals are fitted.

Fig. 36

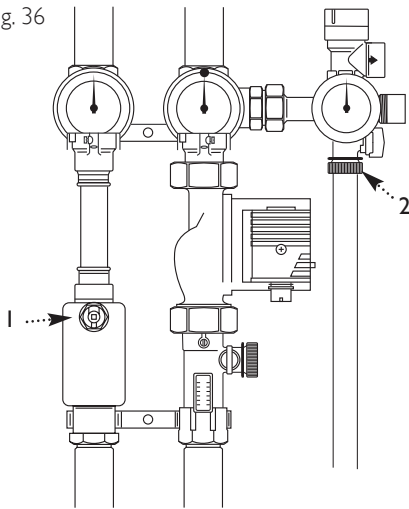

#### Check pressure in the solar primary pipework

- After flushing and filling the solar primary system with heat transfer fluid the pressure must be checked.
- Pressure test the system to between 2 to 2.5 bar. Observe the maximum pressure ratings of all components concerned.
- Check the solar heating system for leaks.
- Close the fill and drain valve on the safety group.

Fig. 37

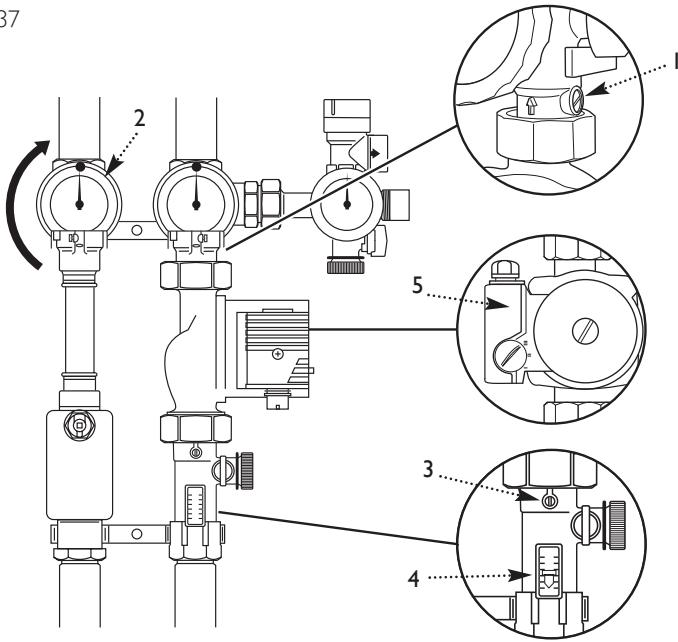
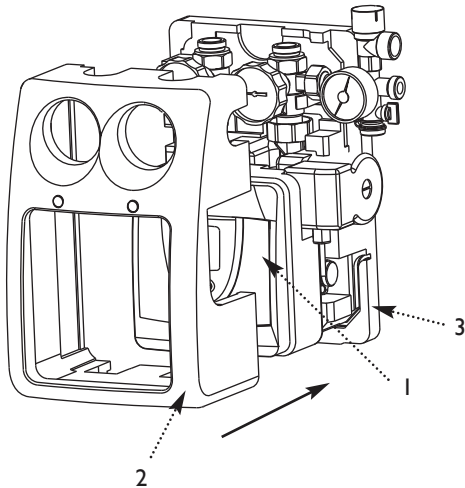

Table 1

Flow rate (when system is cold)	
Collectors	l/min
20	approx. 4
30	approx. 6

Fig. 38



### 13.1 Checking and adjusting the flow rate

1. Adjust the flow rate when the system is cold (20°C) (see Fig. 37).

2. The flow rate should be adjusted to give the optimum flow rate depending on the number and type of collector(s) connected.

3. Manually operate the solar pump (See Section 14.6).

4. Set the solar pump speed selector (Fig. 37 item 5) so that the required flow rate is achieved or exceeded with the lowest possible setting. The flow limiter adjusting screw (Fig. 37 item 3) can be used to fine-tune the flow rate.

5. Depending on the number and type of collectors installed, set the required flow rate from table (See Table 1).

6. The float in the flow meter will indicate the circulation flow rate through the flow meter sight glass (Fig. 37 item 4).

7. Adjust screw of the flow limiter (Fig. 37 item 3) with a screwdriver, until the upper edge of the float in the sight glass indicates the required flow rate (Fig. 37 item 4). Turn the screw anticlockwise to increase the flow.

8. Ensure that the float is stable when the pump is running.

9. Set manual pump operation to off (See Section 14.6).

### 13.2 Installation of the thermal insulation

1. Refit the controller mounting moulding (Fig. 38 item 1) onto the rear moulding.

2. Push the front thermal insulation (Fig. 38 item 2) against the rear thermal insulation section (Fig. 38 item 3) until it clips into place.

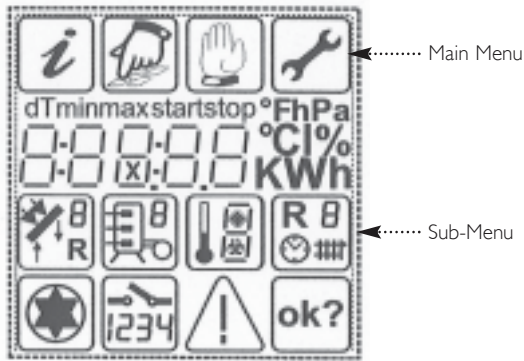

Display Screen

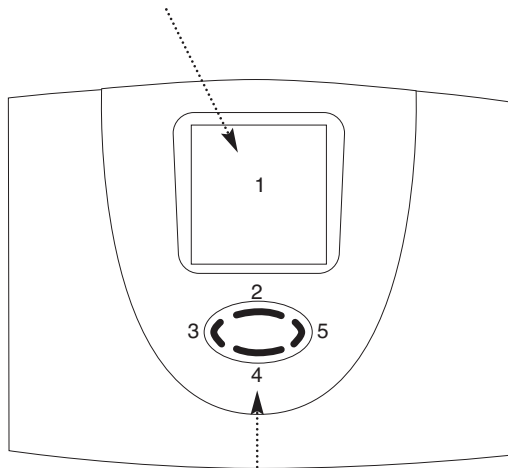

Control Button

- 2 Scroll upwards
- 4 Scroll downwards or select required main menu
- 3 Scroll left or exit to main menu
- 5 Scroll right or select to edit function

Example Screen - Programming Menu



## 14.0 Commissioning of solar controller

### 14.1 Main Menu

To make the operation of the controller clear, operating and display functions are divided into 4 main menus.

Info Indication of current measured values.  
Indication of system condition.  
Indication of error messages.  
Indication of operating hours and energy productivity (if installed).

Programming Changes to programmable values (parameters).

Manual operation Switching on and off connected pumps and auxiliary devices.

**WARNING - During manual operation there is no automatic regulation of the system. Temperature control is isolated. System temperature could be extremely high.**

Basic adjustment Information about basic adjustment for system function. To carry out any changes to this menu it must be selected within the first minute after switching the appliance on.  
**IMPORTANT: Adjustment and changes in this menu must only be carried out by a competent installer or service engineer.**

Each active menu is shown in the upper line of the display by its corresponding icon.

### 14.2 Control Button



When in the Main Menu the control button functions are as follows:

- Item 2 - Scroll upwards- no function in this menu
- Item 3 - Scroll left - moves left through the main menu options
- Item 4 - Scroll down - selects the menu option currently flashing and gives access to the sub-menu
- Item 5 - Scroll right - moves right through the main menu options

Once the sub-menu has been accessed, the flashing symbol becomes static and the button functions are then as follows:

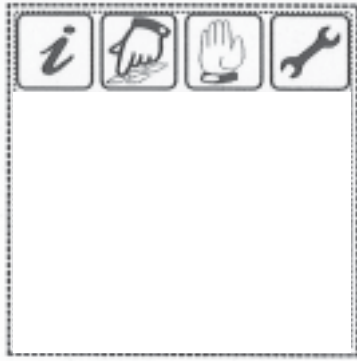
- Item 2 - Scroll upwards- moves up through the available functions of the sub-menu
- Item 3 - Scroll left - return to main menu
- Item 4 - Scroll down - moves down through the available functions of the sub-menu
- Item 5 - Scroll right - select to edit the function displayed. The selected function will flash if it is available for editing. Use 2 to increase the required value and 4 to reduce it. Use 5 to OK.







Press  or  to scroll left or right to the required function. The icon will flash, press  to access the submenu.

## 14.0 Commissioning of solar controller

### 14.3 Overview: Construction of main menu structure

The overview shows the whole menu structure. According to basic adjustment and system type some menu points may not be displayed.

**NOTE:** Items 0 to 3 in the Basic adjustment menu are not applicable to Baxi.

 <b>Info</b>	 <b>Programming</b>	 <b>Manual operation</b>	 <b>Basic adjustment</b>
Current collector temperature / Collector1	DHW Maximum temperature storage cylinder1	Pump1 off / on	0 N/A
Minimum collector temperature / Collector1	Solar pump 'ON' differential dT max (dT on)	Pump2 off / on	1 N/A
Maximum collector temperature / Collector1	Solar pump 'OFF' differential dT min (dT off)	Heating off / on	2 N/A
Current storage cylinder temperature / storage1 at bottom	Maximum temperature of storage cylinder2		3 N/A
Minimum storage cylinder temperature / storage1 at bottom	Storage cylinder2 dT max (dT on)		4 Tube collector off / on
Maximum storage cylinder temperature / storage1 at bottom	Storage cylinder2 dT min (dT off)		5 Solar gain off / on
Current storage cylinder temp / storage2 at bottom / collector 2	N/A		6 Glycol type
Minimum storage cylinder temp / storage2 at bottom / collector 2	Start temperature auxiliary heating		7 Glycol percentage
Maximum storage cylinder temp / storage2 at bottom / collector 2	Hysteresis temperature auxiliary heating / cooling dT		8 Volume flow
Current collector return temperature	N/A		9 Controlling time in seconds
Current temperature auxiliary heating	N/A		10 Storage cylinder priority
N/A	N/A		11 Frost protection off / on
Operating hours pump1	N/A		12 Frost protection sensor assignment
Solar gain kWh	Time period start 1,2,3 for the independent controller; 4 for the tube collector function - min start time 'ON' - max time 'OFF'		13 Frost protection: start temperature
Operating hours pump2	Time period stop 1,2,3 for the independent controller; 4 for the tube collector function		14 Independent controller assignment: Cooling, heating, temperature differential controller
Yield storage2	Set time		15 Sensor assignment for the independent controller
			16 Select basic configuration



Press or to scroll up or down to the required sub function.

The icon will flash, press to select the function. Reset by pressing

or for increase/decrease values. Press

and appears,

press to confirm and disappears.

### 14.4 Menu "Info"

In this menu mode all measured values and operating states are shown.

If the values are marked as "reset possible", they may be reset in the following way:

Choose the value with buttons and

Reset value by means of the button

Message "OK?" confirm with = no or = yes

Indication		Description	Reset possible
75°C		Indication of current collector temperature	no
min. 12°C		Indication of minimum collector temperature Re-settable to current temperature	yes
max. 105°C		Indication of maximum collector temperature Re-settable to current temperature	yes
52°C		Indication of current temperature storage tank (lower)	no
min. 40°C		Indication of minimum temperature storage tank (lower) Re-settable to current temperature	yes
max. 65°C		Frost protection or common measuring point	yes
25°C		Indication of universal temperature measuring points (T3)	no
55°C		Indication of current temperature storage tank thermostat	no
60°C		Indication of current temperature collector return	no
60°C		Heating, Sensor T1...T6	no
1234 h		Operating hours for charging storage tank Resettable to 0 h	Yes
927 kWh		Energy productivity for storage tank Resettable to 0 kWh	Yes

## 14.0 Commissioning of solar controller

### 14.5 Menu "Programming"

All adjustable parameters can be checked in this menu and, if necessary, changed. The default factory setting will usually give efficient and problem free operation. However Baxi recommend the following parameters marked \* must be left at the default settings. Any change to the Baxi recommended settings will invalidate the warranty.

For more information or guidance please contact the Technical Enquiries.

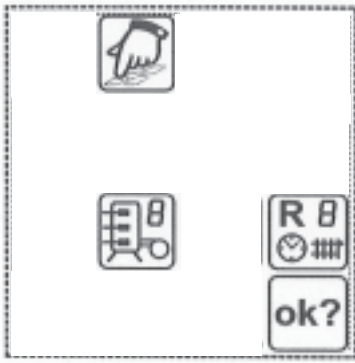

Press or to scroll up or down to the required sub function. The icon will flash, press to select the function. Reset by pressing or for increase/decrease values. Press and appears, press to confirm and disappears.

Indication		Description	Value range	Defaults
max 65°C		Storage 1/2: Maximum temperature	15..95°C	65°C *
dT max 7 K		Storage 1/2: Hysteresis (dT on)	3..40 K	7 K
dT min 3 K		Storage 1/2: Hysteresis (dT off)	2..35 K	3 K
min 100		Setting the speed control of the pump 100% = speed control off	30%..100%	100%
min 40°C		Temperature start for the function heating	20..90°C	40°C
dT 10K		Hysteresis heating	1..30K	10K
(1) min 00:00		Start time 1 for the independent controller	0:00... 23:59	00:00
(1) max 23:59		Stop time 1 for the independent controller	0:00... 23:59	23:59
(2) min 00:00		Start time 2 for the independent controller	0:00... 23:59	00:00
(2) max 23:59		Stop time 2 for the independent controller	0:00... 23:59	23:59
(3) min 00:00		Start time 3 for the independent controller	0:00... 23:59	00:00
(3) max 23:59		Stop time 3 for the independent controller	0:00... 23:59	23:59
(4) min 00:00		Start time 4 for time controlled circulation	0:00... 23:59	00:00
(4) max 23:59		Stop time 4 for time controlled circulation	0:00... 23:59	23:59
13:21		Clock	0:00...23:59	12:00

## 14.0 Commissioning of solar controller



Press or to scroll up or down to the required sub function. The icon will flash, press to select the function. Reset by pressing or for increase/decrease values. Press and **ok?** appears, press to confirm and **ok?** disappears.

### 14.6 Menu "Manual operation"

For commissioning, service and test purposes the solar primary system can be manually operated. For this purpose the switch outputs may be disconnected or connected.

**WARNING - During manual operation there is no automatic regulation of the system. Temperature control is isolated. System temperature could be extremely high. During manual operation there is no automatic regulation of the system.**

To avoid inadmissible operating states this mode of operation changes into "Indication" after approximately 8 hours and the automatic regulation is activated again.

Indication	Description	Value range
	Switching on / off switch output A1 (solar circulation pump)	0 = off 1 = on
	Switching on / off switch output A2 (pump2)	0 = off 1 = on
	Switching on / off switch output A3 (heating)	0 = off 1 = on

## 14.0 Commissioning of solar controller

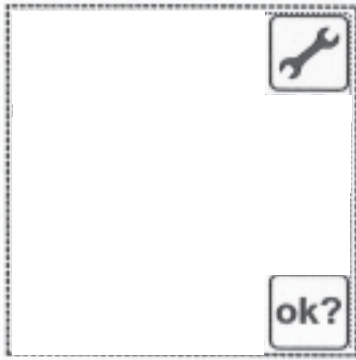

Press or to scroll up or down to the required sub function. The icon will flash, press to select the function. Reset by pressing or for increase/decrease values. Press and **ok?** appears, press to confirm and **ok?** disappears.

### 14.7 Menu "Basic adjustment"

Adjustment and changes in this menu must be carried out only by a competent installer or service engineer.

**Incorrect adjustments may adversely affect the function of controller and solar primary system.**

















To avoid accidental changes in menu "Basic adjustment", it is not editable in normal functioning but has only a display function. To be able to carry out any changes, this menu must be chosen within the first minute after switching on the appliance. **The basic adjustment menu is 'blocked' automatically one minute after switching on if the menu is not accessed.**

Indication Parameter / value	Description	Value range	Factory set-up	Baxi recommend
0 – 0	Collector protection	0 = off 1 = on	N/A	N/A
1 – 120°C	Start temperature for the collector protection	110..150°C	N/A	N/A
2 – 0	Re-cooling function (only when collector protection is on)	0 = off 1 = on	N/A	N/A
3 – 40°C	Target temperature for the storage after collector protection activity	30..90°C	N/A	
4 – 0	Time controlled circulation with tube collectors	0 = off 1 = on	0 = off	0
5 – 0	Solar gain off/on	0 = off 1 = on	0 = off	1
6 – 0	Glycol types (see table below)	0..10	0	10
7 – 50	Glycol percentage	0 ... 100% 5% - steps	50	100
8 – 1,0	Volume flow: Litre per impulse - flow meter	0,5 ... 25 l/l 0,5l - steps	1.0	1.0
9 – 240	Time controlling in s	30...480	240	240
10 – 1	Storage priority	1...2	1	1
11 – 0	Frost protection on/off	0 = off 1 = on	N/A	
12 – 6	Sensor assignment - Frost protection	1...6	N/A	
13 – 3	Start temperature for the frost protection function	-20°C ... +7°C	N/A	
14 – 0	Select cooling thermostat or temperature differential controller	0 = off 1 = cooling 2 = heating	2	2
15 – 5	Auxiliary heating sensor assignment	1...6	5	5
16 – 0	System configuration	0...4	0	0

Glycol types (point 6):

0	Anro	6	Tyfocon L5.5 - supplied
1	Ilexan E, Glythermin	7	Dowcal 10
2	Antifrogen L	8	Dowcal 20
3	Antifrogen N	9	Dowcal N
4	Ilexan E	10	Tyfocon LS
5	Ilexan P		

For correct operation of the system, Baxi recommend the settings shown above.

Graphic symbol	Description	Indication in operation
<b>Measuring points assignment</b>		
	Temperature measuring point collector array 1	
	Temperature measuring point collector array 2	
	Temperature measuring point storage tank 1 solar (storage tank 1 charging)	
	Temperature measuring point storage tank solar (storage tank 2 charging)	
	Temperature measuring point collector - return	
	Temperature measuring point storage tank (auxiliary heating)	
	Antifreezing sensor or universal temperatures measuring point (T6) (no sensor monitoring)	
	Auxiliary heating temperature	
	Operating hours, energy productivity measurement	
<b>Status indication</b>		
	Solar circulation pump	Symbol revolves when solar circulation pump is on
	Switch output 1 is active	Appears when switch output 1 is active (on)
	Switch output 2 is active	Appears when switch output 2 is active (on)
	Switch output 3 is active	Appears when switch output 3 is active (on)
	Reference to system fault	Display flashes when a fault occurs in the system
	Safety query for value changes which are to be stored	Input value can be either  rejected or  accepted

14.8 Overview of display and operating elements  
(cont)

Graphic symbol	Description	Indication in operation
<b>Indicator values</b>		
<b>dT</b>	Temperature difference	
<b>min</b>	Min value	Appears when minimum values are indicated
<b>max</b>	Max value	Appears when maximum values are indicated
<b>min</b> <b>0:00</b> <b>I</b>	Time period I start	Appears when the differential controller is active (timeframe 1-3) or tube collector is active (timeframe 4)
<b>Max</b> <b>23:59</b> <b>I</b>	Time period I stop	Appears when the differential controller is active (timeframe 1-3) or tube collector is active (timeframe 4)
	5 x 7 segment display. Presentation of figures 00000 to 99999	Display of all values, display flashes when a value is changed
<b>°C</b>	Temperature in Celsius	
<b>K</b>	Temperature difference in Kelvin	
<b>h</b>	Operating hours	
<b>kWh</b>	Productivity indication in kWh	

### 14.9 Controller functions

The Baxi Solarflo differential temperature controller contains many functions to regulate and monitor the solar primary system. Including

- controller functions for heating the solar cylinder
- functions for system protection and system monitoring
- additional functions (other accessories may be required to achieve these functions).

### 14.10 General controller functions

The controller collects the temperatures of various measuring points and determines the right time to charge the storage tank on account of programmed (additional) functions and controller parameters.

### 14.11 Cylinder heating by solar primary system

Switching action can be adjusted through  $dT_{max}$  ( $dT_{on}$ ) and  $dT_{min}$  ( $dT_{off}$ ), but  $dT_{on}$  cannot be set lower than  $dT_{off} + 1K$ . The solar cylinder is heated by operating the solar pump on output A1 up to the set maximum storage temperature (recommended  $65^{\circ}C$ ). Pump operation is allowed as long as the collector temperature exceeds the cylinder temperature by the amount set in the programming menu.

Corresponding values in menu
“Programming”
Maximum temperature
$dT_{max}$ ( $dT_{on}$ ) Switch-on temperature difference
$dT_{min}$ ( $dT_{off}$ ) Switch-off temperature difference

### 14.12 Systems with two storage cylinders

For systems with more than one storage cylinder (System Types 1 and 2) the cylinder heating can be optimised depending on the energy supply. Usually the cylinder with lower priority will have a lower temperature than that with the higher priority. Re-directing the energy to the lower priority cylinder will lower the temperature in the collector array. To “reinforce” the collector temperature the heating of the lower priority cylinder will be interrupted for a short while at fixed intervals. If the heating criteria for the higher priority cylinder is fulfilled then the lower priority cylinder will be heated. The higher priority cylinder can be selected in the “Basic Adjustment” menu point no. 10.

### 14.13 Rotational speed regulation

The solar circulation pump on 230V-outputs A1 and A2 can be operated either in switch-mode (two-point controller) or in a rotational speed regulated way.

If the rotational speed regulation is activated the pump power is adjusted by a controller so that switch-on temperature difference "Storage tank dTmax" is kept constant as much as possible. At lower deviation of "Storage tank dTmax" the pump is operated with the lowest power till the switch-off wave is reached.

Corresponding values in menu	
"Basic adjustment"	"Programming"
---	Rotational speed min <100%

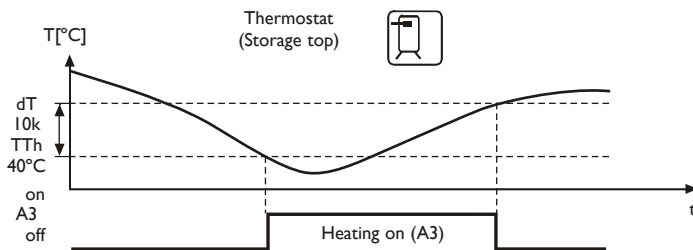

### 14.14 Thermostat (heating)

The thermostat is a control circuit that's independent from the storage loading. Thus an auxiliary heating in the top area of the storage cylinder is made possible. The output A3 will be:

- Switched on, when the temperature falls below the adjusted start level.
- Switched off, when the temperature reaches the adjusted start level + hysteresis.

Corresponding values in menu	
"Basic adjustment"	"Programming"
14 -- 2	Start temperature max °C
15 -- 5	Hysteresis dT in K
	Time period (1...3) Start: min time
	Time period (1...3) Stop: max time

### 14.15 Thermostat (cooling)

In order to optimise the energy yield, it could be useful to "redirect" the solar energy, or to take it away from the storage when the storage temperature reaches a pre-set level.

When the sensor reaches the start temperature, output A3 will be switched on. When the temperature level falls below the start temperature hysteresis, the output A3 will be switched off.

Corresponding values in menu	
"Basic adjustment"	"Programming"
14 -- 1	Start temperature max °C
15 -- 5	Hysteresis dT in K
	Time period (1...3) Start: min time
	Time period (1...3) Stop: max time

### 14.16 Tube collector

The function “tube collector” can be switched off/on in the “Basic setting” menu – point 4. The timeframe 4 in the “Program” menu makes it possible to activate this function only for a certain period of time. When activated, the solar pump will be switched on every 30 minutes for a period of 30 seconds. This is necessary, to measure a temperature change in the collector if there was no circulating for a long period of time.



Corresponding values in menu	
“Basic Setting”	“Programming”
4 -- 1	Time period (4) Start: min time
	Time period (4) Stop: max time

### 14.17 Sensor monitoring

The sensors necessary for control functions and their connecting cables are monitored regarding break and short circuit. If a faulty sensor is recognised by the software, the symbol  is shown. By scrolling up and down you can find an error source.



The use of temperature sensors of the wrong type can also lead to an error message

Indication	Meaning
	Short circuit on temperature sensor of the current measuring point
	Break on temperature sensor of the current measuring point, circulation error at activated energy productivity measurement

### 14.18 Flow monitoring

If the energy productivity measurement option is deactivated, the temperature difference between collector and storage tank is checked.

If it exceeds the amount of  $(60K + dT_{max})$ , it is then interpreted as an error because in the case of normal system dimensioning and a pump switched on such large differences cannot take place.

If the energy productivity measurement option is activated, the flow amount when the pump is switched on is checked. If for 15 minutes no flow is recognised it is evaluated as an error. Error message is automatically reset after eliminating the failure.

Indication	Meaning
	Missing circulation in solar circuit

### 14.19 System protection function

The system protection function switches the system off if the "maximum collector temperature" is exceeded by 10K. As soon as the temperature drops below the "maximum collector temperature", the system is started up again. This function has higher priority and is always active, regardless of whether the collector protection is on or off.

### 14.20 Frost protection

This function can be switched on/off in the "Basic adjustments" menu, point 11 and the start temperature can be adjusted in point 13. Furthermore, a frost protection sensor can be selected (T1-T6, point 12).

If the measured value is lower than the start temperature, the solar pump is activated until the adjusted frost protection start temperature +5K is reached. The minimum runtime of the pump is 5 minutes.

For security reasons the function is deactivated if the temperature of the priority storage falls below 5°C.

### 14.21 Energy productivity measurement

For the purposes of energy productivity measurement (solar gain), a sensor on the collector return line and a flow meter are required. The yield value is calculated from the values of the temperature difference between the collector and collector return line and the value measured by the flow meter. This function is switched on and off in the "Basic settings" menu.

Corresponding values in menu		
"Basic Setting"	"Programming"	"info"
5 -- 1	---	XXXX kWh

### 14.22 Operating hours meter

So long as the storage tank is charged by a pump, the operating hours meter records for each separate pump. The number of operating hours can be read in menu "info" and for each pump separately reset to 0.

Corresponding values in menu	
"Programming"	"info"
---	XXXX h

The following chart should be completed during Commissioning of the system.

Installer: \_\_\_\_\_ BPEC No.: \_\_\_\_\_  
 Contact details: \_\_\_\_\_ Serial Nos. Cylinder \_\_\_\_\_  
 Original installation date: \_\_\_\_\_ Collector \_\_\_\_\_ Pump Station \_\_\_\_\_

<b>General Commissioning</b>	
All pipework correctly installed, identified and earth bonded	<input type="checkbox"/>
Solar primary system filled with heat transfer fluid supplied	<input type="checkbox"/>
System pressure test carried out	<input type="checkbox"/>
Solar expansion vessel charge pressure checked and set	<input type="checkbox"/> bar
Air vented from system	<input type="checkbox"/>
Exposed pipework insulated using high-temp and weather resistant insulation	<input type="checkbox"/>
Panel fixing bracket positions weatherproofed where necessary	<input type="checkbox"/>
Panel fixings checked and secure	<input type="checkbox"/>
<b>Hydraulic Station</b>	
System pressure when cold	bar
Solar primary flow when cold	l/min
Isolating/non-return valves (flow and return) in operating position	<input type="checkbox"/>
<b>Solar Collector</b>	
Collectors visually inspected for defects	<input type="checkbox"/>
Collectors temperature sensor correctly installed and secured	<input type="checkbox"/>
Pipe entry points to building weatherproof	<input type="checkbox"/>
<b>Solar Differential Temperature Controller</b>	
Record all operational parameters set (see separate table)	<input type="checkbox"/>
Pump operation tested in automatic and manual modes	<input type="checkbox"/>
All cables correctly installed and secured	<input type="checkbox"/>
Suitably fused isolating device installed	<input type="checkbox"/>
<b>Solar Cylinder</b>	
Cylinder installed and commissioned in accordance with cylinder installation instructions	<input type="checkbox"/>

**Solar differential temperature controller - operational parameters**

If any factory values are changed please enter the new values in the table below.

<b>Adjustable in menu "Programming"</b>	Typical adjustment	Current adjustment
Storage tank1: Maximum storage temperature	65°C	*
Storage tank1: switch-on difference (dTon)	7 K	
Storage tank1: switch-off difference (dToff)	3 K	
Storage tank2: Maximum storage temperature	90°C	*
Storage tank2: switch-on difference (dTon)	7 K	
Storage tank2: switch-off difference (dToff)	3 K	
Minimum pump power on rotational speed regulation	100%	
Switch-on temperature of thermostat function	40°C	
Hysteresis of thermostat function	10 K	
2nd temperature differential controller maximum temperature Tmax	65°C	
2nd temperature differential controller hysteresis dTmax	7 K	

<b>Adjustable in menu "Basic adjustments"</b>	Typical adjustment	Current adjustment
Switching on or off the function collector protection	0 = off	*
Temperature at which the collector protection function is active	120°C	*
Switching on or off the function recooling (only when the collector protection is on)	0 = off	*
Temperature to which the storage tank is recooled when collector protection function is on	40°C	*
Function for time-controlled circulation in operation with tube collectors	0 = off	
Switching on or off the function energy productivity measurement	0 = off	
Choice of glycol types used	0 = Anro	
Mixture ratio of coolants	50%	
Litres per impulse of the flowmeter	1.0 L/l	
Switching on or off the function antifreezing	0 = off	
Temperature at which the antifreezing is active	-1°C	
Alternative choice of the cooling, thermostat function or the 2nd temperature differential controller	0 = none	
System type	type 0	
Time control in secs	240	
Storage priority	I	

\* Baxi recommends these settings are left at the default value.

**Servicing and maintenance record**

Please complete the following record after any Servicing or Maintenance of the Baxi Solarflo system. Refer to the Commissioning Record charts for details of the original system for reference. Refer to Maintenance section for recommended Maintenance periods

	Date / /	Date / /	Date / /	Date / /	Date / /	Date / /	Date / /	Date / /	Date / /	Date / /	Date / /	Date / /	Date / /	Date / /
Check condition of all pipework	<input type="checkbox"/>	<input type="checkbox"/>	<input type="checkbox"/>	<input type="checkbox"/>	<input type="checkbox"/>	<input type="checkbox"/>	<input type="checkbox"/>	<input type="checkbox"/>	<input type="checkbox"/>	<input type="checkbox"/>	<input type="checkbox"/>	<input type="checkbox"/>	<input type="checkbox"/>	<input type="checkbox"/>
Check condition of insulation	<input type="checkbox"/>	<input type="checkbox"/>	<input type="checkbox"/>	<input type="checkbox"/>	<input type="checkbox"/>	<input type="checkbox"/>	<input type="checkbox"/>	<input type="checkbox"/>	<input type="checkbox"/>	<input type="checkbox"/>	<input type="checkbox"/>	<input type="checkbox"/>	<input type="checkbox"/>	<input type="checkbox"/>
Check frost protection of solar fluid (every 2 years) Concentration Protection to °C Next check date	— — —	— — —	— — —	— — —	— — —	— — —	— — —	— — —	— — —	— — —	— — —	— — —	— — —	— — —
Check solar expansion vessel charge pressure	bar	bar	bar	bar	bar	bar	bar	bar	bar	bar	bar	bar	bar	bar
Check solar primary system pressure (cold)	bar	bar	bar	bar	bar	bar	bar	bar	bar	bar	bar	bar	bar	bar
Check solar primary system flow rate	l/min	l/min	l/min	l/min	l/min	l/min	l/min	l/min	l/min	l/min	l/min	l/min	l/min	l/min
Check operation of PRV	<input type="checkbox"/>	<input type="checkbox"/>	<input type="checkbox"/>	<input type="checkbox"/>	<input type="checkbox"/>	<input type="checkbox"/>	<input type="checkbox"/>	<input type="checkbox"/>	<input type="checkbox"/>	<input type="checkbox"/>	<input type="checkbox"/>	<input type="checkbox"/>	<input type="checkbox"/>	<input type="checkbox"/>
Check sensor operation (use resistance/temperature table. See page 22)	<input type="checkbox"/>	<input type="checkbox"/>	<input type="checkbox"/>	<input type="checkbox"/>	<input type="checkbox"/>	<input type="checkbox"/>	<input type="checkbox"/>	<input type="checkbox"/>	<input type="checkbox"/>	<input type="checkbox"/>	<input type="checkbox"/>	<input type="checkbox"/>	<input type="checkbox"/>	<input type="checkbox"/>
Check solar cylinder in accordance with manufacturer's instructions	<input type="checkbox"/>	<input type="checkbox"/>	<input type="checkbox"/>	<input type="checkbox"/>	<input type="checkbox"/>	<input type="checkbox"/>	<input type="checkbox"/>	<input type="checkbox"/>	<input type="checkbox"/>	<input type="checkbox"/>	<input type="checkbox"/>	<input type="checkbox"/>	<input type="checkbox"/>	<input type="checkbox"/>
Ensure system is free of air	<input type="checkbox"/>	<input type="checkbox"/>	<input type="checkbox"/>	<input type="checkbox"/>	<input type="checkbox"/>	<input type="checkbox"/>	<input type="checkbox"/>	<input type="checkbox"/>	<input type="checkbox"/>	<input type="checkbox"/>	<input type="checkbox"/>	<input type="checkbox"/>	<input type="checkbox"/>	<input type="checkbox"/>
Visually check condition of solar collectors	<input type="checkbox"/>	<input type="checkbox"/>	<input type="checkbox"/>	<input type="checkbox"/>	<input type="checkbox"/>	<input type="checkbox"/>	<input type="checkbox"/>	<input type="checkbox"/>	<input type="checkbox"/>	<input type="checkbox"/>	<input type="checkbox"/>	<input type="checkbox"/>	<input type="checkbox"/>	<input type="checkbox"/>
Visually check condition of collector brackets and fixings (every 2 years)	<input type="checkbox"/>	<input type="checkbox"/>	<input type="checkbox"/>	<input type="checkbox"/>	<input type="checkbox"/>	<input type="checkbox"/>	<input type="checkbox"/>	<input type="checkbox"/>	<input type="checkbox"/>	<input type="checkbox"/>	<input type="checkbox"/>	<input type="checkbox"/>	<input type="checkbox"/>	<input type="checkbox"/>
Visually check condition of any waterproofing (around pipe entries to roof and roof fixings)	<input type="checkbox"/>	<input type="checkbox"/>	<input type="checkbox"/>	<input type="checkbox"/>	<input type="checkbox"/>	<input type="checkbox"/>	<input type="checkbox"/>	<input type="checkbox"/>	<input type="checkbox"/>	<input type="checkbox"/>	<input type="checkbox"/>	<input type="checkbox"/>	<input type="checkbox"/>	<input type="checkbox"/>
Engineers initials	—	—	—	—	—	—	—	—	—	—	—	—	—	—
BPEC Number	—	—	—	—	—	—	—	—	—	—	—	—	—	—



## 16.0 Maintenance

---

### 16.1 Check heat transfer fluid

The heat transfer fluid must be checked every year with regard to its antifreeze and pH value.

- Check antifreeze using antifreeze tester. Target value is approximately -21 deg C (40% concentration).
- 

### 16.2 Maintenance of the collector

The collector or the collector array must be checked/serviced annually to check for any damage, leaks and contamination.

---



### 16.3 Cylinder

Refer to manufacturers documentation.

---

### 17.1 Failures with error message

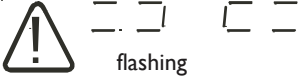
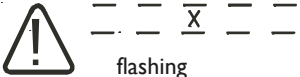
Some system failure modes can be recognised by the solar differential temperature controller and will be indicated by an error message on the controller display. Refer to the table below for details of possible errors and suggested measures to rectify.

Error representation on display	Possible reasons	Measures
 flashing	• Sensor wire broken	• Check wire
	• Sensor defect	• Check sensor resistance, if necessary exchange sensor
 flashing	• Short circuit in sensor wire	• Check wire
	• Sensor defect	• Check sensor resistance, if necessary exchange sensor
Circulation error: no flow  flashing  Additionally at energy productivity measurement: 	• Error in pump connection	• Check cabling
	• Pump defect	• Exchange pump
	• Air in the system	• Check the float of the flow meter moves when the system runs (if visible)
	• Connection with flow meter defect	• Check wire
	• Sensor wire broken	• Check wire
	• Sensor defect	• Check sensor resistance, if necessary exchange sensor

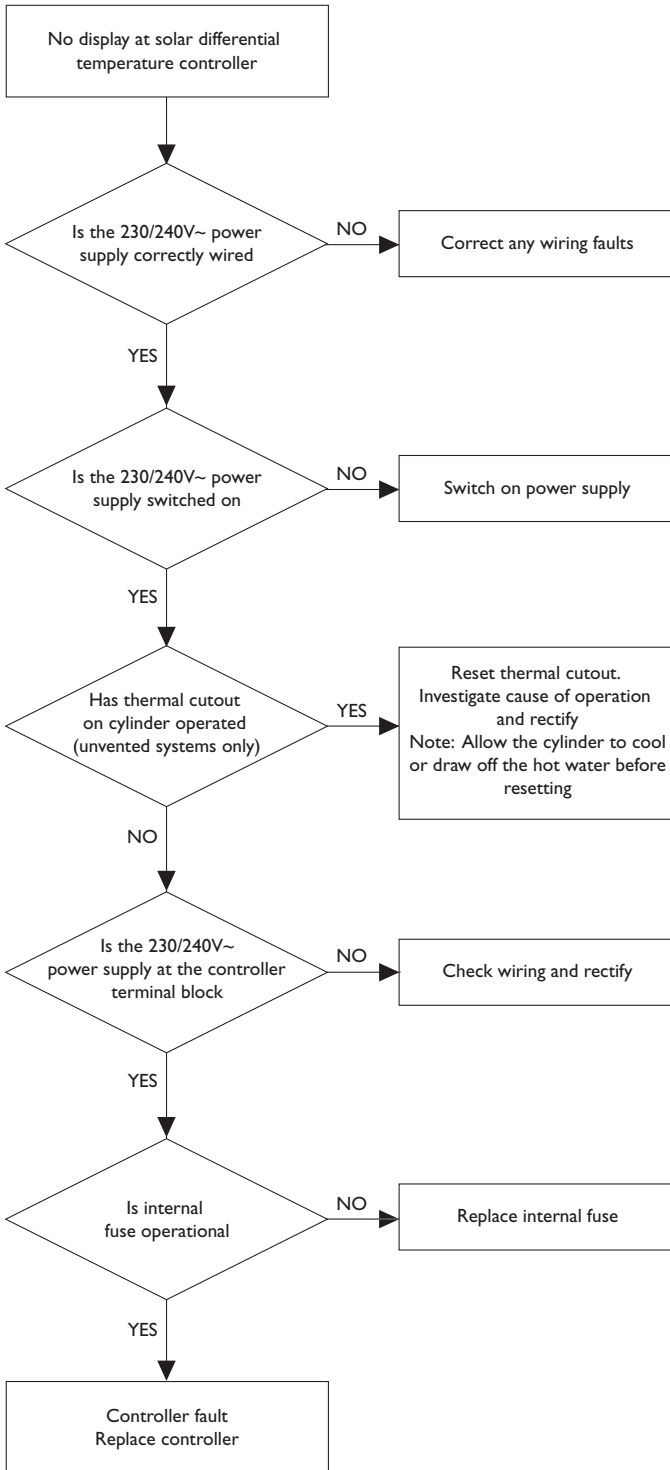

Resistance table PT1000.

The correct function of temperature sensors can be checked on the basis of the following temperature resistance table with a resistance measuring instrument:

Temperature in °C	Resistance in Ohm
-30	882
-20	921
-10	960
0	1000
10	1039
20	1077
30	1116
40	1155
50	1194
60	1232
70	1271
80	1309
90	1347
100	1385
120	1461
140	1535
200	1758

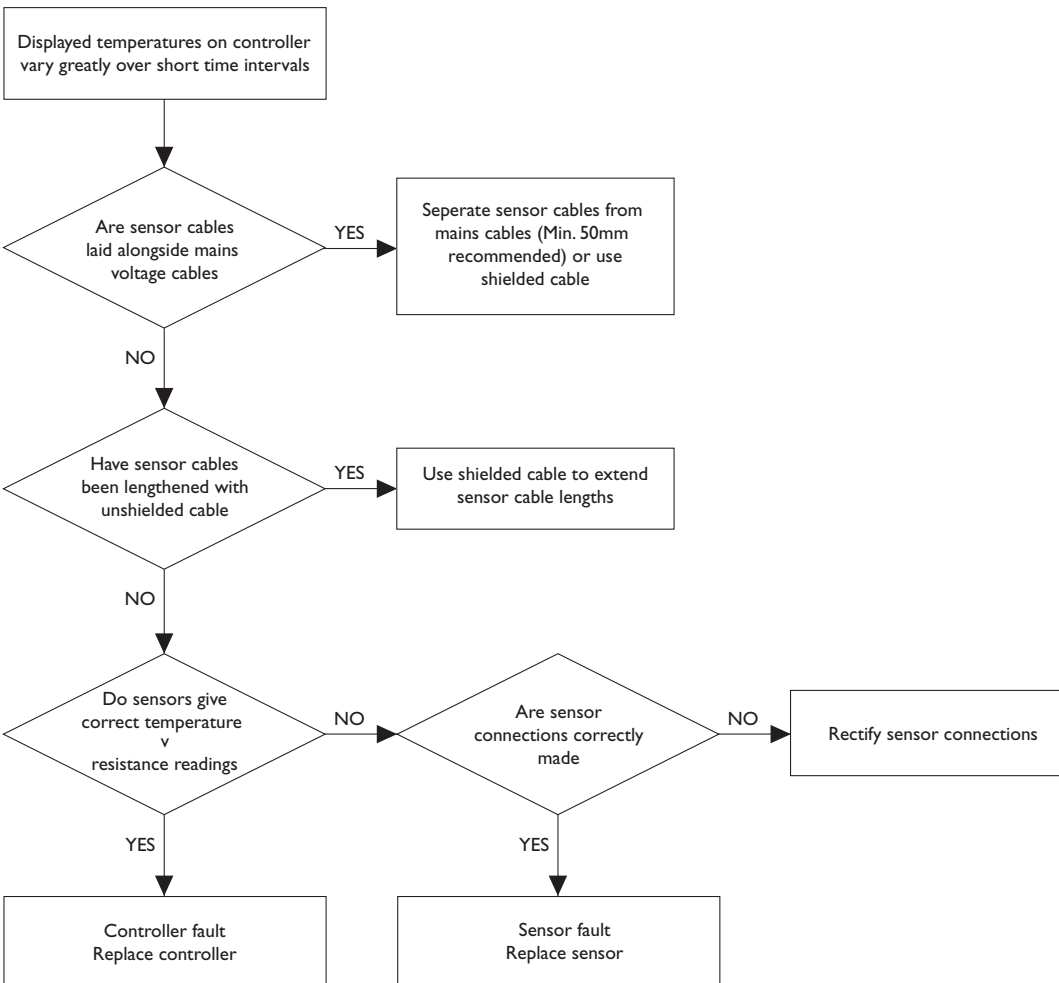
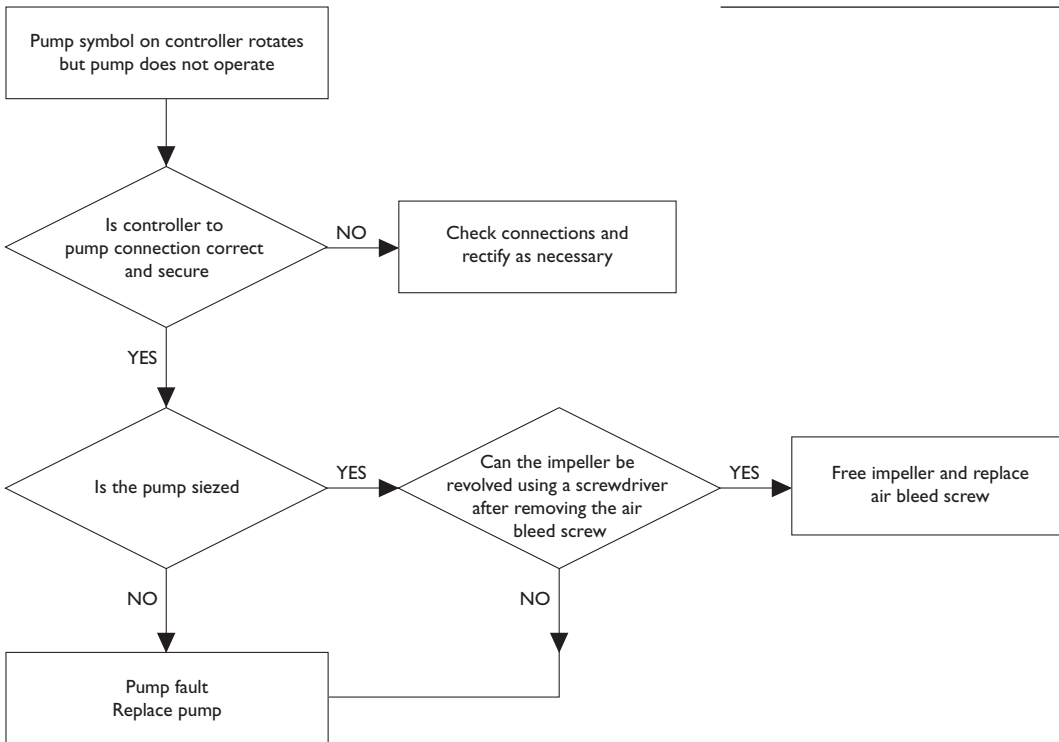

## Short Parts List

Key No.	Description	Manufacturer's Part No.
A	Bracket Foot	5130637
B	Clamp Manifold Vertical	5130640
C	Clamp Manifold Horizontal	5132704
D	Clamp Support Rail	5130641
E	Bracket Rear Foot	5130638
F	Clip Manifold Connection	5130643
G	O-ring Manifold Connection	5130644
H	Clip Tube Retainer	5130645
J	O-ring Evac Tube	5130646
K	Clamp Rubber Evac Tube	5130647
L	DF100 Evac Tube 1 off	5130648
M	Tee Piece Manifold	5132722
N	Fluid Tyfocor LS Solar 20Ltr (Not Illustrated)	5130225
O	Bracket Roof	5130639
P	Sensor Pocket Manifold	5132723

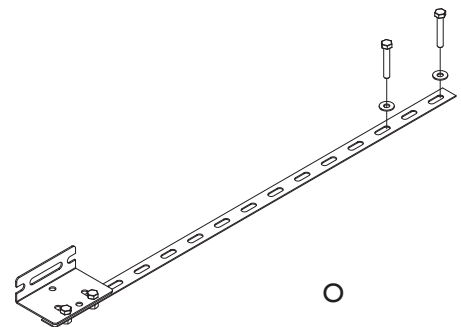
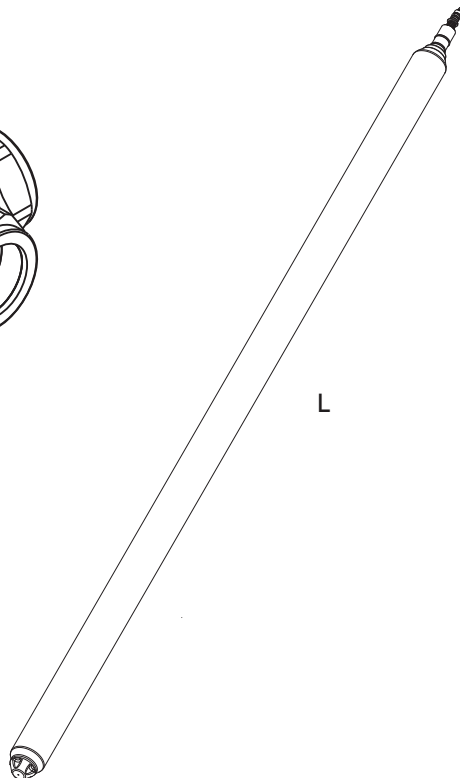
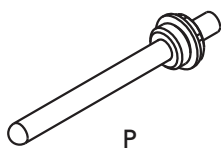
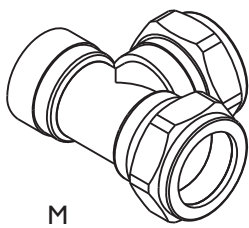
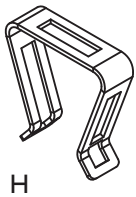
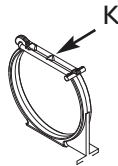
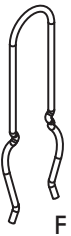
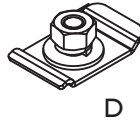
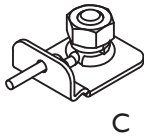
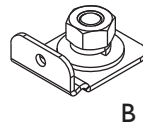
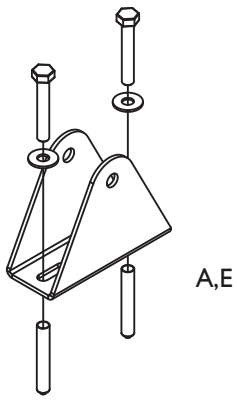

## 18.0 Spares

### Spares Parts

A number of Spare Parts are available should any part of the Solarflo system require replacement. Use only genuine parts obtained from Baxi, use of other non Baxi parts may cause system malfunctions and will invalidate the warranty. Fitting of any spare parts must be carried out by a competent installer or authorised service engineer or agent.

### Short Parts List

Key No.	Description	Manufacturer's Part No.
AI	Connection Washer	5119535
BI	Temperature Sensor	5119536
CI	Solar Differential Temperature Controller	5119537
DI	Pressure Relief Valve	5119538
EI	Pressure Gauge	5119539
FI	Safety Group	5119540
GI	Solar Primary Circulating Pump	5119541
HI	Flow Meter Assembly	5119542
JI	Temperature Gauge	5119543
KI	Solar Expansion Vessel 24Litres	5119548
LI	Expansion Vessel Self-sealing Connection	5119779

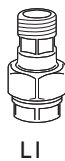
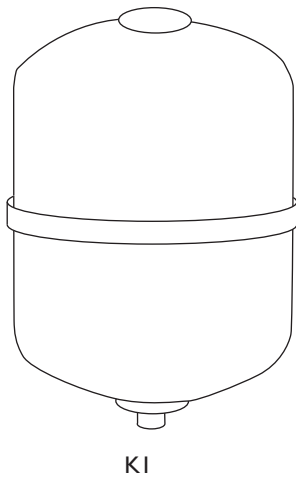
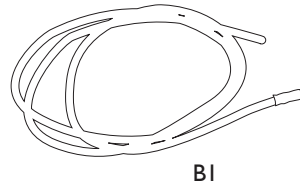
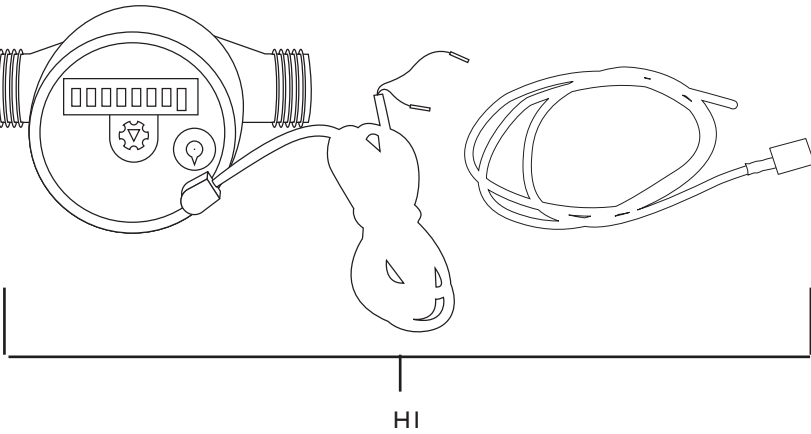
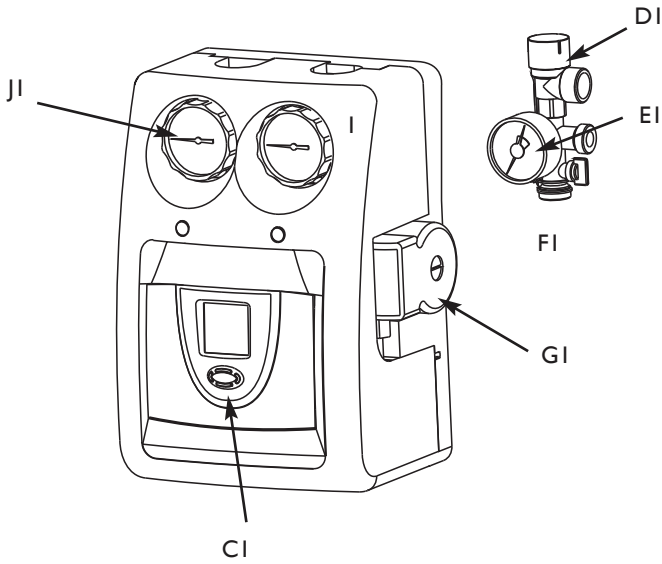

### 19.1 Standard Warranty Terms & Conditions

Solar Collectors 5 Years  
Solar Control Station 2 Years

To receive your free warranty please complete the form supplied with the Baxi Solarflo™ system within 30 days of installation, or simply call heateam, the service division of Baxi Heating UK Ltd on 0844 871 1568

#### **Our promise to you**

If you experience a fault with your new Solarflo system, we aim to provide a safe and high quality repair service supported by our dedicated national network of highly skilled engineers. If your installer can't resolve the problem for you, we will do everything we can to get an engineer out to you as quickly as possible. Nothing in this warranty will affect your statutory consumer rights.

#### **What you need to do if you experience a problem with your Baxi Solarflo™ system.**

You should always contact your installer first because the fault may not be related to the Baxi Solarflo™ system. If your installer confirms that the fault is within the Baxi Solarflo™ system itself and he/she decides they cannot repair it our friendly customer service team is on hand to help. Simply call our service division heateam on 0844 871 1568 to book an engineer visit or for any general advice that you may need. Our contact centre is open Monday to Friday 8am - 6pm, weekends and Bank Holidays 8.30am - 2pm, excluding Christmas Day and New Years Day.

#### **When calling heateam you must have the following information to hand: -**

- Baxi Solarflo™ system serial numbers
- Baxi Solarflo™ system model number
- Your installer name, address details and contact details
- Proof of purchase (if you do not have the Baxi Solarflo™ serial number)

All descriptions and illustrations provided in this leaflet have been carefully prepared but we reserve the right to make changes and improvements in our products which may affect the accuracy of the information contained in this leaflet. All goods are sold subject to our standard Conditions of Sale which are available on request.

## **MULTIFIT**

A Registered Trademark of Baxi Heating UK Ltd (3879156)

**Brooks House, Coventry Road, Warwick. CV34 4LL**

**Technical Enquiries 0844 871 1568**

**Our contact centre is open Monday to Friday 8am to 6pm,  
Weekends and Bank Holidays 8.30am to 2pm.**

**We are closed Christmas Day and New Years Day.**

**Website [www.bdrthermea.com](http://www.bdrthermea.com)**

**e&oe**

PART OF BDR THERMEA

Comp No 5132038 - Issue 2 - 5/11