

BAXI

Megaflo System HE A



A
SEDBUK
Band A





Bringing contemporary style to the latest high efficiency technology.

We can't see it, but we can feel it: heat has always been one of life's essentials. And having warmed people's homes for over 150 years, Baxi knows a thing or two about it. With a Baxi boiler at the heart of your heating system, you know that vital warmth will be produced as efficiently as possible, backed by our passion for technology and our commitment to the environment.

The Baxi Megaflo System HE A effortlessly combines high efficiency and excellent environmental credentials with high performance and style.

The Baxi Megaflo System HE A turns over 90% of fuel into heat, so it has the highest SEDBUK Band 'A' rating. And while that has a big impact on your fuel bills, it also means less of an impact on the environment.

The Baxi Megaflo System HE A has been designed for fully pumped sealed systems, and many of the system's major components are already built into the boiler – such as the pump and an expansion tank (so you don't need one in your loft) – therefore installation is quicker, neater, easier and cheaper.





Because your hot water is provided via a storage cylinder, you'll have plenty available no matter how many taps you turn on; and as the Baxi Megaflo System HE A is fully modulating, it automatically adapts to a wide variety of applications.

We know you want a boiler that looks good and is easy to use too, so we've given it soft curves, a chrome strip and stylish high gloss finish. Controls are simple and easy to use too, featuring clear rotary knobs and a bright LED display.

There are five models in the Baxi Megaflo System HE A range: 15kW, 18kW, 24kW, 28kW and 32kW.

And whichever you choose, you can be sure it'll give you all the heat and hot water you need – and more.

Note - Legislation: To meet new Building Regulations, your heating system may need additional controls. After fitting, you should get a Building Regulations compliance certificate from CORGI to show the work is to the right standard. Keep this, as you may need it when you come to sell your house.

Key features & benefits:

- SEDBUK Band 'A' Rated - means reduced fuel bills compared to traditional boilers
- 2 year parts and labour product warranty* for peace of mind
- Contemporary design
- Fully modulating and suitable for many applications
- Clear, simple rotary output and mode selectors

*Subject to registration and an annual service.

Dimensions and clearances

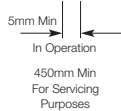
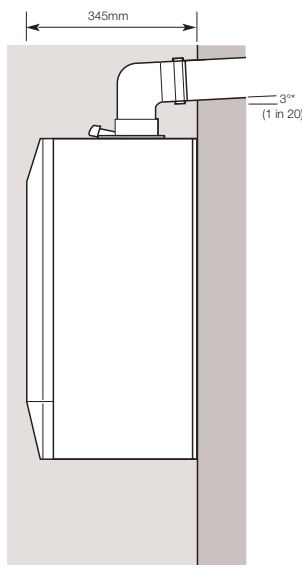
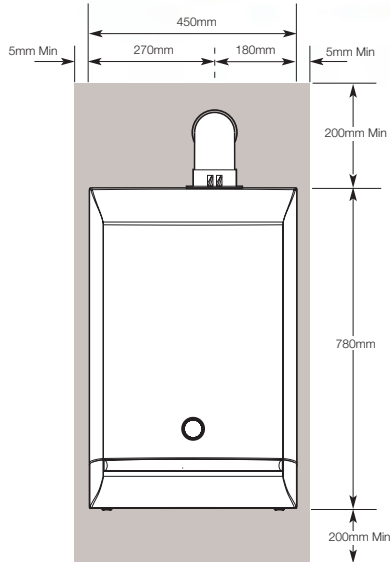

Baxi Megaflo System HE A:						
Wall mounted high efficiency boilers		15 kW	18 kW	24 kW	28 kW	32 kW
CONTROLS						
Concealed User Controls		Yes	Yes	Yes	Yes	Yes
Operating Mode Selector Switch with Reset		Yes	Yes	Yes	Yes	Yes
User Adjustable CH Temperature		Yes	Yes	Yes	Yes	Yes
LED Temp/Status/Fault Diagnosis Display		2 digits & 3 LEDs				
GAS						
Heat Output CH Non Condensing (70°C mean)	kW (Max)	15	18	24	28	32
	kW (Min)	3.9	4.2	6.8	9.4	9.4
Heat Output CH Condensing (40°C mean)	kW (Max)	16.2	19.4	25.9	30.3	34.4
	kW (Min)	4.2	4.5	7.4	10.2	10.2
SEDBUK Rating Band		A	A	A	A	A
NOx Class		5	5	5	5	5
NOx Levels	mg/kWh	27.5	31.7	22.3	21.8	26.8
ELECTRICAL						
Power Consumption watts		130	140	150	160	160
Integral 'Boiler Only' Frost Thermostat		Yes	Yes	Yes	Yes	Yes
MECHANICAL & HYDRAULIC						
Compartment Ventilation Requirement		None	None	None	None	None
Stand Off Kit (For Pipe Runs Behind Boiler)		Optional Extra	Optional Extra	Optional Extra	Optional Extra	Optional Extra
Pre-plumbing Jig		Yes	Yes	Yes	Yes	Yes

* The 3 degree fall back on concentric flues can be reduced to 1.5 degrees providing the flue system is adequately clamped in accordance with the installation instructions.

For all enquiries, please call
0844 871 1525

Open Monday – Friday, 8am – 6pm

Weekends and Bank Holidays, 8.30am – 2pm

We are closed on Christmas Day and New Years Day

Please note calls may be monitored or recorded.



Baxi. A Baxi Group Company.
Brooks House, Coventry Road,
Warwick CV34 4LL

www.baxi.co.uk

B/Megaflo/C/Aug08/V3



ISO 9001
FM 00866



ISO 14001
EMS 514880



Baxi policy is one of continual improvement and development. The right to change specification and appearance without prior notice is reserved. The e&oe reproduction of colours is as accurate as photographic and printing processes allow. The consumer's statutory rights are not affected.

Manufacturing address: Baxi Group, Club Street, Bamber Bridge, Preston, PR5 6FN.
A trading division of Baxi Heating UK Ltd, a division of Baxi Group.